



WARNING!



SAFETY INSTRUCTIONS

1. Depressurize and vent system prior to installation or removal.
2. Confirm chemical compatibility before use.
3. Do not exceed maximum temperature/pressure specifications.
4. Wear safety goggles or faceshield during installation/service.
5. Do not alter product construction.
6. When using chemicals or solvents, care should be taken and appropriate eye, face, hand, body, and/or respiratory protection should be used.

Contents

- | | |
|---|--|
| 1. Description | 7. Wiring Dual Digital Output (S ³ L) version |
| 2. Specifications | 8. Cell Constant Selection |
| 3. In-Line Installation | 9. Range Selection for 4 to 20mA Output |
| 4. Submersible Installation | 10. Calibration |
| 5. Wiring 4-20 mA Output version | 11. Maintenance |
| 6. Wiring Digital Output (S ³ L) version | 12. Ordering Information |

1. Description

Signet 2850 Conductivity/Resistivity Sensor Electronics provides a two-wire 4 to 20 mA output, or a digital interface in S³L™ format. The 4 to 20 mA output models provide eight ranges for each electrode cell constant, plus the ability to invert each range. The Easy-Cal feature allows the devices to automatically recognize standard conductivity test solution values for simple field calibration.

2. Specifications

General

Compatible Electrodes: All Signet models with PT-1000 RTD

Materials and Shipping Weight:

- Integral mount: PBT: 0.75 kg (1.75 lb.)
- Remote mount: PBT, CPVC: 0.75 kg (1.75 lb.)

Temperature Compensation: PT-1000 RTD

Easy-Cal:

Automatic recognition of the following conductivity values:

- 146.93 µS, 1408.8 µS, 12856 µS (@25°C)
(Test solutions Per ASTM D1125-95)
- 10 µS, 100 µS, 200 µS, 500 µS, 1000 µS, 5000 µS,
10,000 µS, 50,000 µS, 100,000 µS (@25°C)

Electrical

Power: 12 to 24 VDC for 4 to 20 mA output
5 VDC +/-5% regulated, 3.0 mA max. for Digital (S³L)
output (Reverse polarity and short circuit protected)

- Digital (S³L) Output: Serial ASCII, TTL level 9600 bps
- Accuracy: Conductivity: ±2% of reading
Temperature: ±0.5°C
 - Resolution: Conductivity: 0.1% of reading

- Update Rate: Temperature: <0.2°C
Single channel models: <600 ms
Dual channel models: <1.2 s

Available data via Digital (S³L) Output:

- Raw conductivity
- Calibrated conductivity
- Calibrated temperature-compensated conductivity
- Temperature

Error Indication: Open input and out of range diagnostics for temperature or internal electronic error.

Current Output:

- Field-selectable ranges
- Factory set Span:
 - 0.01 cell (2819, 2839): 4 to 20 mA = 0 to 100 μ S
 - 0.10 cell (2820, 2840): 4 to 20 mA = 0 to 1000 μ S
 - 1.0 cell (2821, 2841): 4 to 20 mA = 0 to 10,000 μ S
 - 10.0 cell (2822, 2842): 4 to 20 mA = 0 to 200,000 μ S
 - 20.0 cell (2823): 4 to 20 mA = 0 to 400,000 μ S
- Max. Loop Resistance: 50 Ω @ 12 VDC
325 Ω @ 18 VDC
600 Ω @ 24 VDC
- Accuracy: $\pm 2\%$ of output span
- Resolution: 7 μ A
- Update Rate: <600 ms
- Error Indication: 22 mA

Standards and Approvals

- NEMA 4X/IP65
- CE
- Immunity: EN61326-1
- Emissions: EN55011 Class B
- Manufactured under ISO 9001 and ISO 14001

Dimensions

2850-51, -52 Integral mount

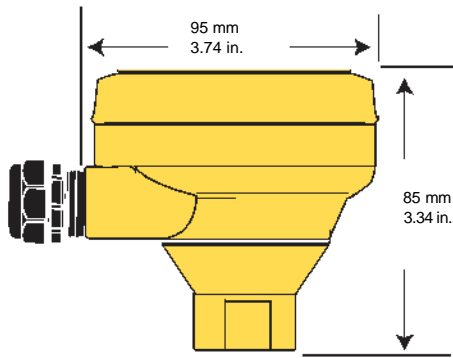

2850-61, -62, -63 Universal mount

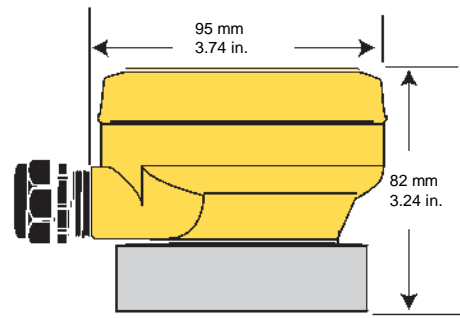

Conductivity Sensor Dimensions

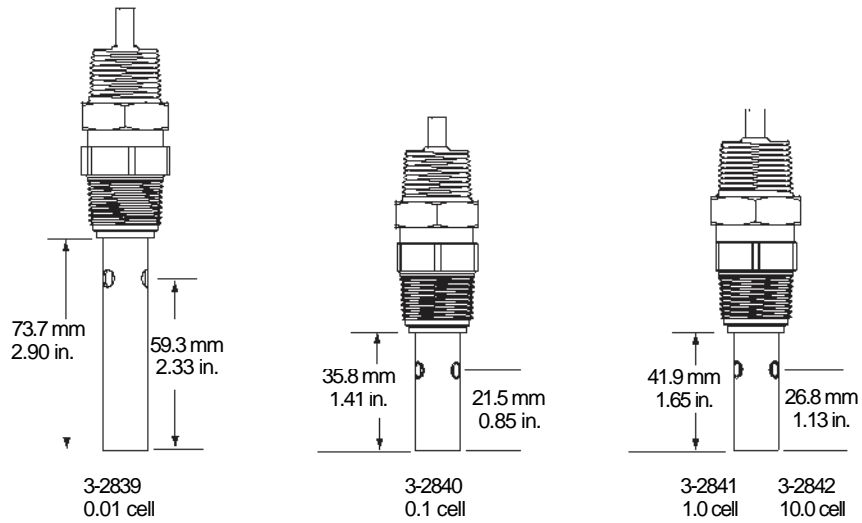

Operating Range Chart

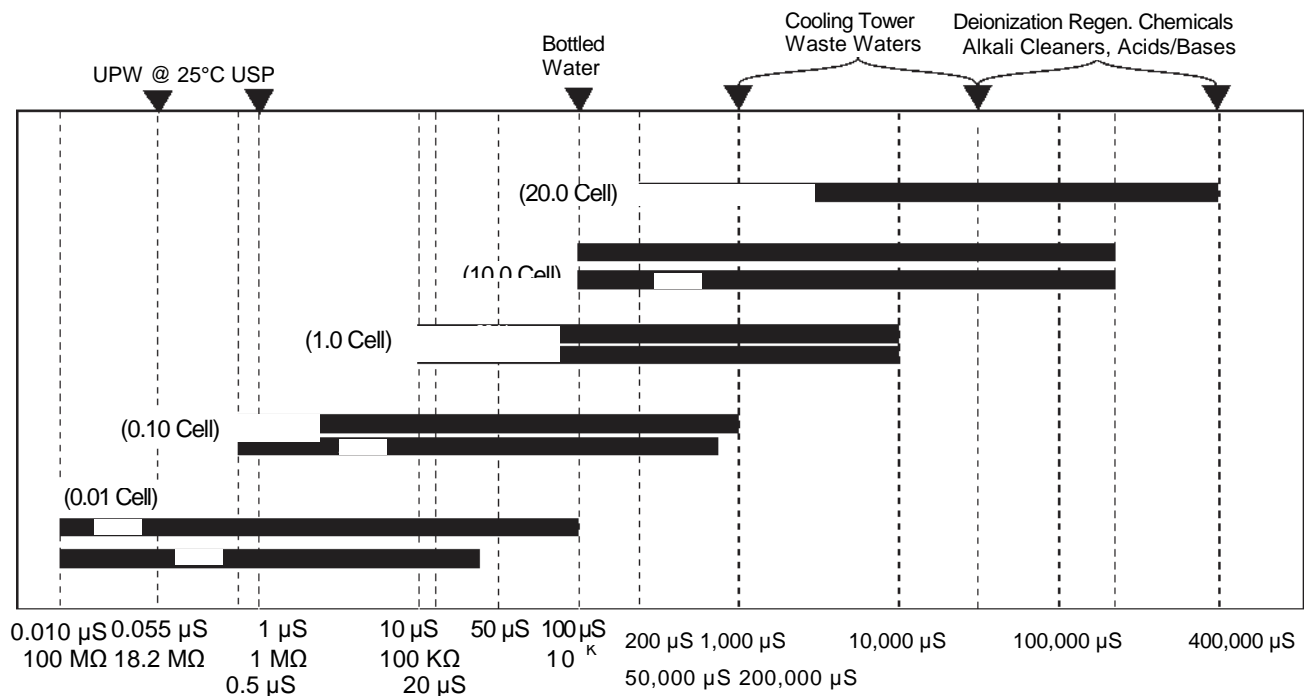

3. In-Line Installations

Most of the Conductivity/Resistivity electrodes used with the 2850 can be installed into standard $\frac{3}{4}$ in. (NPT or ISO 7-R $\frac{3}{4}$) fittings.

The 2850-5X models are designed for integral systems, where the electronics are attached directly to the sensor. For these models, select any electrode with a short (6 inch) cable.

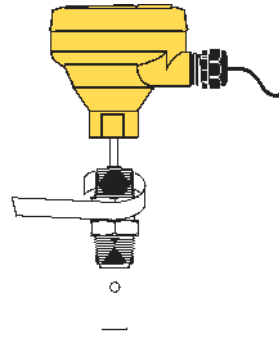

The preferred installation for in-line applications directs flow straight into the electrode. This configuration reduces the probability of entrapped air bubbles, and provides the best continuous sampling of the fluid content.

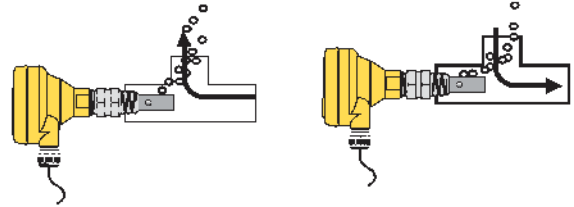

If the electrode is mounted vertically in a tee, do not recess the electrode orifices inside the tee. Mounting upside down may help prevent air entrapment.

An oversized tee or flow cell may be helpful for inline installations. At least 4 threads (ANSI B1 .20.1) must be engaged to meet the pressure rating as published in the specifications.

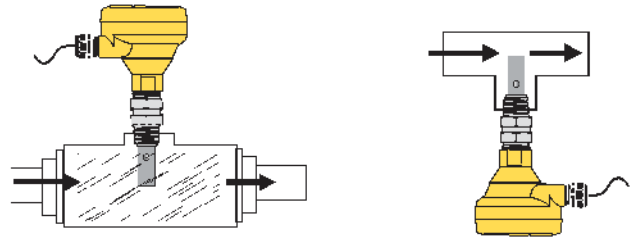

Use the 2850-6X models for in-line installations where the electronics must be separated from the electrode. Conductivity electrodes with sanitary flange fittings must be installed using this option.

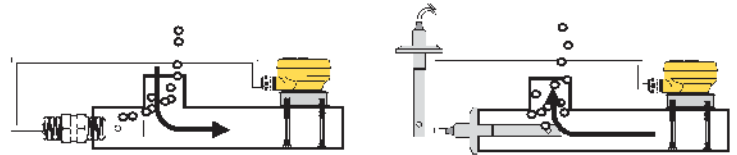

4. Tank Installations

While the 2850-5X and -6X electronics cannot be submerged, either model will accommodate tank installation.

Select any electrode with a 5 m (15 ft.) cable. The cable may be cut to length, but it **CANNOT BE EXTENDED**.

The universal adapter included with 2850-6X models can be attached to the top of a tank or mounted to a surface near the tank.

Adapt the 2850-5X models to tank installations by attaching a clamp to the conduit.

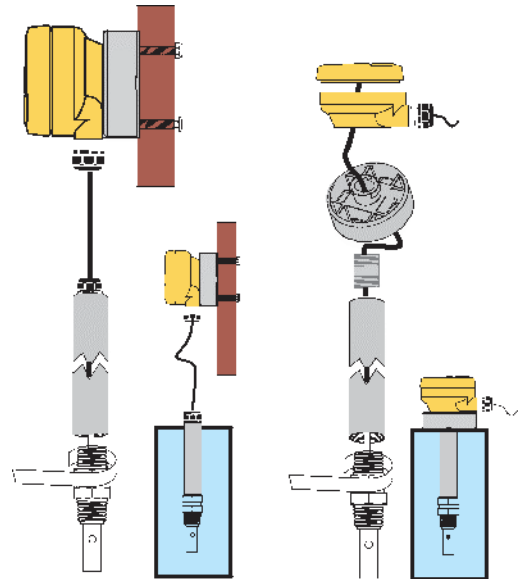
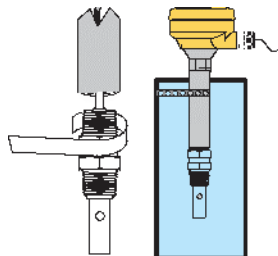
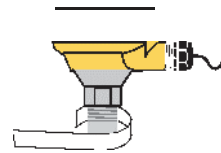

5. Wiring 4-20 mA Output version

- Maximum length of 4-20 mA loop is 300 meters (1000 ft.)

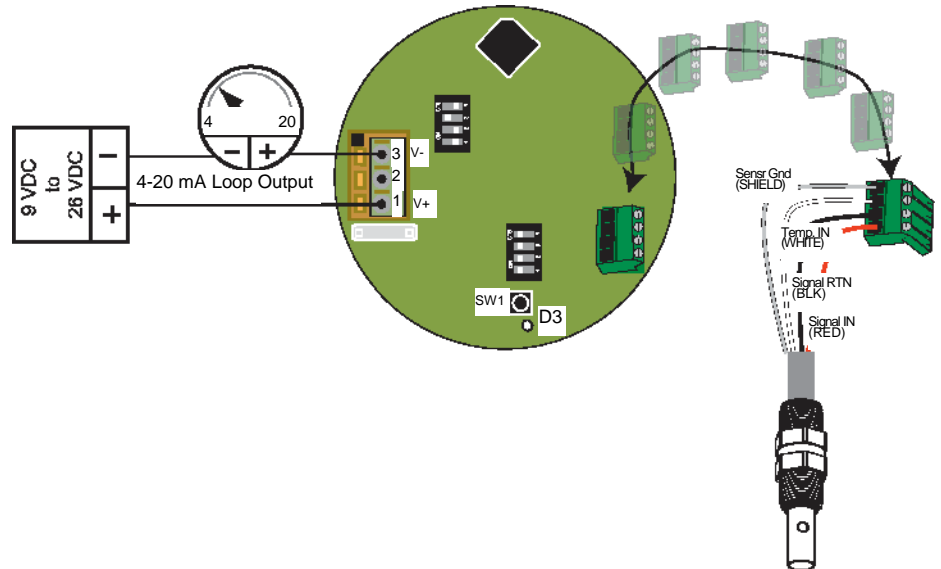

6. Wiring Digital Output (S³L) version

- The digital output is compatible with the Signet 8900 Multi-Parameter Controller.
- Refer to the wiring section of the 8900 manual to determine cable length limitations.

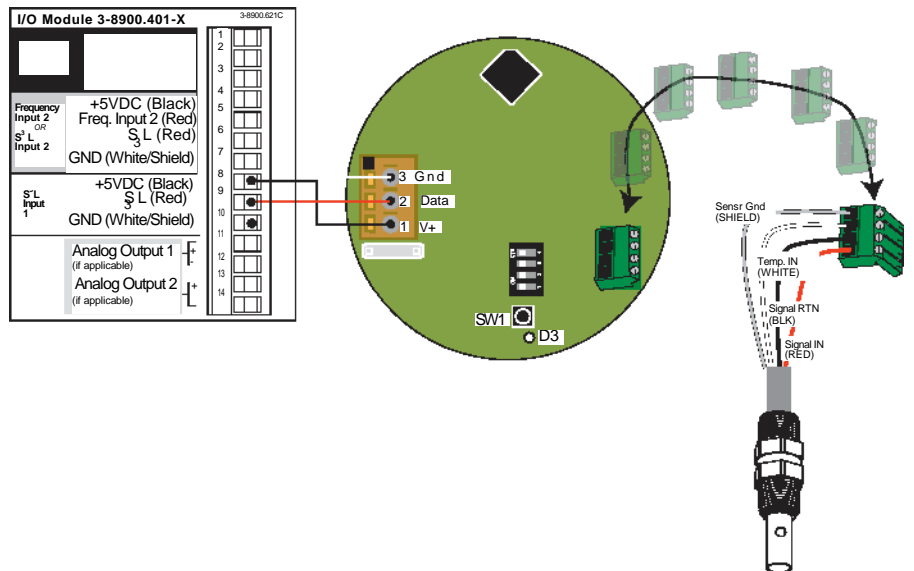

7. Wiring Dual Digital Output (S³L) version

- Dual channel input is available on digital models only.
- Sensors may be the same or different cell constants.
- If a dual channel model is used with a single sensor, connect it to channel 1, and set all of the channel 2 switches to OFF.

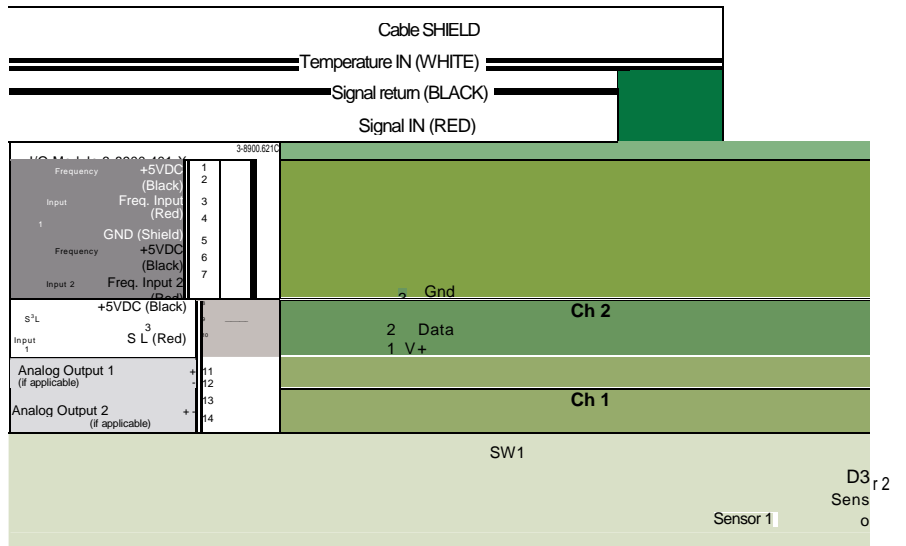

8. Cell Constant Selection

Cell Constant Selection

- Switch banks SW3 and SW4 are used to select the CELL CONSTANT of the electrode. The Dual Input model is illustrated. Single input models use only SW3.
- Make all switch settings before connecting power. Switch changes made with the power ON will take 15-20 seconds before becoming effective.
- Use SW3 #1-3 to select the cell constant for the first sensor.
- Use SW3 #4 to disable the PT1000 Temp Compensation function in the 2850 (as required for USP applications.) This disables the function for BOTH CHANNELS.
- Use SW4 #1-3 to select the cell constant for the second sensor.
- Set SW4 #4 to OPEN to disable the second channel.

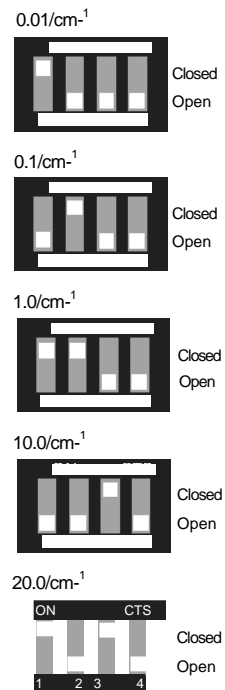
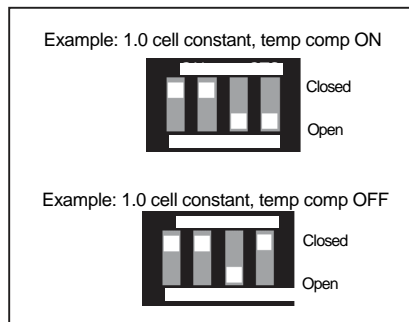
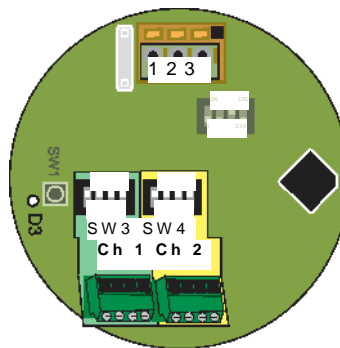

SW3 Cell Constant and Temp Compensation				
#1	#2	#3	#4	For Cell Constant
C	O	O	O	0.01/cm ⁻¹
O	C	O	O	0.1/cm ⁻¹
C	C	O	O	1.0/cm ⁻¹
O	O	C	O	10.0/cm ⁻¹
C	O	C	O	20.0/cm ⁻¹
#4:		Open = Temp Comp ON Closed = Temp Comp OFF		
SW4: #1, #2 and #3 operate the same as SW3. #4 turns channel 2 OFF when set to OPEN. (Open = Off, Closed = On)				

9. Range Selection for 4 to 20mA Output

The Range selection switch bank (SW2) provides eight range selections for each cell constant. Each range can be inverted, making a total of 16 range options.

Select a range from the table below and set SW2 as indicated.

Example (refer to shaded selections of chart):

- The electrode installed is the 3-2840-1, with a 0.10 cell constant.
- The required output is 4-20 mA = 0-100 μS.
- Set SW2 switch bank to C-C-O-O.
- To invert range (4-20 mA = 100-0 μS), Close switch #4.

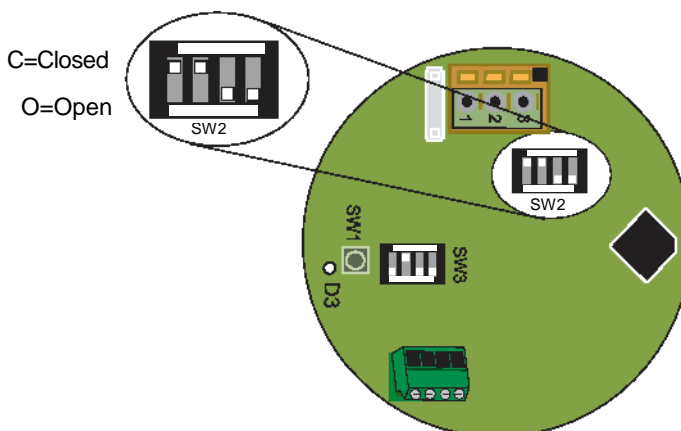

SW2 Switch setting				0.01 Cell	0.10 Cell	1.0 Cell	10.0 Cell	20.0 Cell
#1	#2	#3	#4	Resistivity Ranges in BOLD				
C	C	C	O	10 to 20 MΩ	0 to 2 μS	0 to 20 μS	0 to 200 μS	0 to 400 μS
C	C	C	C	20 to 10 MΩ	2 to 0 μS	20 to μS	200 to 0 μS	400 to 0 μS
O	C	C	O	2 to 10 MΩ	0 to 5 μS	0 to 50 μS	0 to 500 μS	0 to 1000 μS
O	C	C	C	10 to 2 MΩ	5 to 0 μS	50 to 0 μS	500 to 0 μS	1000 to 0 μS
C	O	C	O	0 to 2 MΩ	0 to 10 μS	0 to 100 μS	0 to 1 000 μS	0 to 2000 μS
C	O	C	C	2 to 0 MΩ	10 to 0 μS	100 to 0 μS	1 000 to 0 μS	2000 to 0 μS
O	O	C	O	0 to 1 μS	0 to 50 μS	0 to 500 μS	0 to 5 000 μS	0 to 10000 μS
O	O	C	C	1 to 0 μS	50 to 0 μS	500 to 0 μS	5 000 to 0 μS	10000 to 0 μS
C	C	O	O	0 to 5 μS	0 to 100 μS	0 to 1 000 μS	0 to 10 000 μS	0 to 20 000 μS
C	C	O	C	5 to 0 μS	100 to 0 μS	1 000 to 0 μS	10 000 to 0 μS	20 000 to 0 μS
O	C	O	O	0 to 10 μS	0 to 200 μS	0 to 2 000 μS	0 to 50 000 μS	0 to 100 000 μS
O	C	O	C	10 to 0 μS	200 to 0 μS	2 000 to 0 μS	50 000 to 0 μS	100 000 to 0 μS
C	O	O	O	0 to 50 μS	0 to 500 μS	0 to 5 000 μS	0 to 100 000 μS	0 to 200 000 μS
C	O	O	C	50 to 0 μS	500 to 0 μS	5 000 to 0 μS	100 000 to 0 μS	200 000 to 0 μS
O	O	O	O	0 to 100 μS	0 to 1 000 μS	0 to 10 000 μS	0 to 200 000 μS	0 to 400 000 μS
O	O	O	C	100 to 0 μS	1 000 to 0 μS	10 000 to 0 μS	200 000 to 0 μS	400 000 to 0 μS
C = CLOSED O = OPEN				Switch #4 inverts the output: OPEN = 4-20 mA, CLOSED = 20-4 mA				

10. Calibration

- All 2850 Conductivity/Resistivity Sensor Electronics are factory-calibrated for maximum out-of-the-box accuracy.
- The Easy-Cal feature allows calibration to be performed at the sensor.

- SW2: 4-20 mA output range selection switch bank
- Power and 4 to 20 mA or Digital (S³L) output terminal block
- SW3 and SW4: Electrode Cell Constant selection switch banks
- D3: LED indicator
- SW1: Easy-Cal Push-button
- Conductivity Electrode connections

CH 2

f

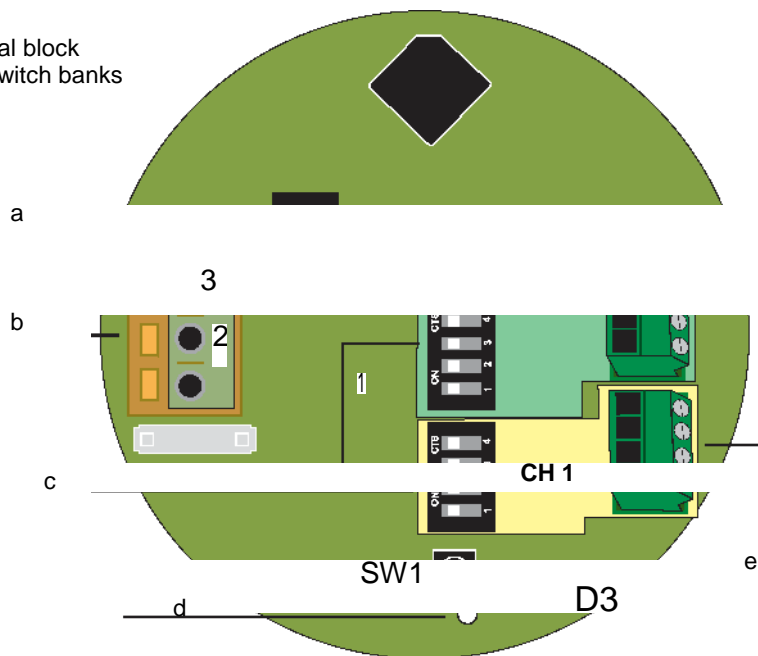

10.1 Easy-Cal

Easy-Cal is a single-point calibration system. During this procedure, if the measured value is within $\pm 10\%$ of any of the test values listed below, the 2850 will automatically recognize the test value and calibrates the output to that value.

Note:

The first step (Reset) is recommended each time an electrode is replaced, but is NOT necessary upon initial installation or periodic calibration.

- 1. Reset** the 2850 Sensor to factory calibration: Set all switches on SW3 (and SW4 for dual input) to OPEN. Apply power, wait at least 3 seconds, then press and hold SW1 until the LED (D3) comes on steady then goes off again (approx. 10 seconds). When the LED goes off, release SW1; reset is complete. Reset SW3 and SW4 to the proper settings.
- 2. Place** the electrode/sensor assembly into the conductivity test solution appropriate to your operating range. Shake the electrode to dislodge any air bubbles visible on the surface of the electrode.
 - 146.93 μS , 1408.8 μS , 12856 μS (per ASTM D1125-95)
 - 10 μS , 100 μS , 200 μS , 500 μS , 1000 μS , 5000 μS , 10,000 μS , 50,000 μS , 100,000 μS
 - Allow at least 2 minutes for the electrode response to stabilize.
- 3. Press** and hold SW1 for approximately 8 to 10 seconds. During this time, the LED will come on steady then go back off. (If the LED blinks several times rapidly, the calibration was not successful. See the troubleshooting section.)

Calibration is complete. Return the system to service.

Calibrating the Dual-channel model 3-2850-63

- The 2850-63 can only be calibrated if both channels are used, or if channel 2 is disabled.
 - To disable channel 2: Set SW4, #4 to OPEN.
- Place each sensor into a test solution that represents the operating range of that sensor. When SW1 is pressed, the 2850 will calibrate both channels simultaneously.
- Dual channel applications usually include one sensor with a smaller cell constant and one sensor with a larger cell constant. Place the larger cell constant on channel 1. This allows periodic recalibration of the larger cell by simply turning channel 2 OFF.

11. Maintenance

- The 2850 requires no periodic maintenance.
- Coatings on the electrode may cause slow response or drift.
Clean metallic surfaces with a mild detergent and a non-abrasive brush or cotton swab.

11.1 Troubleshooting

LED and Output Condition	Possible Causes	Suggested Solutions
Current Out: LED off, current output is 22 mA S³L out: "Check Sensor"	<ul style="list-style-type: none"> • SW3 and SW4 set to all OPEN (factory setting) • No electrode installed • SW3 (and SW4) not set correctly • System not ready 	<ul style="list-style-type: none"> • Normal for new system • Install electrode • Set SW3 and SW4 correctly • Retry (recycle power)
During EasyCal, the LED blinks rapidly for 4 seconds.	<ul style="list-style-type: none"> • Measured value of the test solution is outside the $\pm 10\%$ tolerance. • The electronics or the electrode is defective. 	<ul style="list-style-type: none"> • Use fresh test solutions and restart the calibration. • Replace the electronics or the electrode.
After completing calibration procedure, the output values are inaccurate.	<ul style="list-style-type: none"> • Insufficient time allowed for electrode stabilization during Cal procedure. • Test solutions are contaminated. • EZ-Cal performed with temp comp OFF, then temp comp turned ON for measurement. (or vice versa) 	<ul style="list-style-type: none"> • Recalibrate and wait at least 2 minutes after placing electrode in solution before pressing SW1. • Use fresh test solutions and restart the calibration.
The output of the 2850 indicates a value that is off by a factor of 10 (ie: 10x, 100x the correct value)	<ul style="list-style-type: none"> • The cell constant selection on the 2850 (SW3 or SW4) does not match the actual input. 	<ul style="list-style-type: none"> • Match the 2850 switch settings to agree with the sensor being used.

Electronic Certification/Calibration

Signet offers conductivity simulators in five different values. These tools enable the user to validate the performance of the electronics independently of the electrode. This requirement is defined by ASTM D 1125-95 (Standard Test Methods for Electrical Conductivity and Resistivity of Water) which is commonly used for USP 24 applications.



3-2850.101-1 (159 001 392)	1.0 $\mu\text{S} \pm 0.1\%$	3-2850.101-2 (159 001 393)	2.5 $\mu\text{S} \pm 0.1\%$
3-2850.101-3 (159 001 394)	10.0 $\mu\text{S} \pm 0.1\%$	3-2850.101-4 (159 001 395)	18.2 $\text{M}\Omega \pm 0.1\%$
3-2850.101-5 (159 001 396)	10.0 $\text{M}\Omega \pm 0.1\%$		

Before using the Simulator:

Before using the simulators, disconnect all electrodes and reset the 2850 Electronics to factory calibration:

1. Set all switches on SW3 (and SW4 for dual input) to OPEN. Turn the power on, wait at least 3 seconds
2. Press and hold SW1 until the LED (D3) comes on steady then goes off again (approx. 10 seconds).
3. When the LED goes off, release SW1. Reset is complete.

To validate channel 1:

1. Turn the power off.
2. Set SW3 to accept a 0.01 cell constant. Leave SW4 in the all-OPEN position.
3. Install the simulator into the 2850 at the channel 1 conductivity electrode terminals.
4. Connect the 2850 output terminals to the appropriate display instrument. Turn the power on.
 - The display should indicate a conductivity value within $\pm 2\%$ of the simulator value.
 - If the output is x10 or x100 of the correct value, recheck step 2. The 2850 is not set to accept a 0.01 cell constant.
 - If the correct value is displayed, the electronics are calibrated to ASTM D 1125 specifications. Remove the simulator and reset SW3 to the correct cell constant before reinstalling the electrode.
 - If the correct value is not displayed, contact the factory.

To validate channel 2:

1. Turn the power off.
2. Set SW4 to accept a 0.01 cell constant.
3. Install the simulator into the 2850 at the channel 2 conductivity electrode terminals.
4. Set SW3 switches to the all-OPEN position.
5. Turn the power on and repeat step 4.

Remember to reset all switches to their correct position before resuming normal operation.

12. Ordering Information

Mfr. Part No.	Code	Description
3-2850-51	159 001 398	2850 Sensor Electronics w/ Digital Output and ¼ inch adapter
3-2850-52	159 001 399	2850 Sensor Electronics w/ 4-20 mA Output and ¼ inch adapter
3-2850-61	159 001 400	2850 Sensor Electronics w/ Digital Output and Universal adapter
3-2850-62	159 001 401	2850 Sensor Electronics w/ 4-20 mA Output and Universal adapter
3-2850-63	159 001 402	2850 Sensor Electronics w/ Dual Inputs, Digital Outputs and Universal adapter
3-2850-51-39	159 001 339	Integral 2850 system, Digital (S ³ L) output, 0.01 cell, NPT threads
3-2850-51-40	159 001 340	Integral 2850 system, Digital (S ³ L) output, 0.1 cell, NPT threads
3-2850-51-41	159 001 341	Integral 2850 system, Digital (S ³ L) output, 1.0 cell, NPT threads
3-2850-51-42	159 001 342	Integral 2850 system, Digital (S ³ L) output, 10.0 cell, NPT threads
3-2850-51-39D	159 001 343	Integral 2850 system, Digital (S ³ L) output, 0.01 cell, ISO threads
3-2850-51-40D	159 001 344	Integral 2850 system, Digital (S ³ L) output, 0.1 cell, ISO threads
3-2850-51-41D	159 001 345	Integral 2850 system, Digital (S ³ L) output, 1.0 cell, ISO threads
3-2850-51-42D	159 001 346	Integral 2850 system, Digital (S ³ L) output, 10.0 cell, ISO threads
3-2850-52-39	159 001 347	Integral 2850 system, 4-20 mA output, 0.01 cell, NPT threads
3-2850-52-40	159 001 348	Integral 2850 system, 4-20 mA output, 0.1 cell, NPT threads
3-2850-52-41	159 001 349	Integral 2850 system, 4-20 mA output, 1.0 cell, NPT threads
3-2850-52-42	159 001 350	Integral 2850 system, 4-20 mA output, 10.0 cell, NPT threads
3-2850-52-39D	159 001 351	Integral 2850 system, 4-20 mA output, 0.01 cell, ISO threads
3-2850-52-40D	159 001 352	Integral 2850 system, 4-20 mA output, 0.1 cell, ISO threads
3-2850-52-41D	159 001 353	Integral 2850 system, 4-20 mA output, 1.0 cell, ISO threads
3-2850-52-42D	159 001 354	Integral 2850 system, 4-20 mA output, 10.0 cell, ISO threads

Parts and Accessories

Mfr. Part No.	Code	Description
3-9000.392-1	159 000 839	Liquid-tight connector kit, 1 set, ½ in. NPT
3-9000.392-2	159 000 841	Liquid-tight connector kit, 1 set, PG 13.5
3-9000.392-3	159 001 430	Liquid-tight connector kit, dual-cable gland
3-2850.101-1	159 001 392	Plug-in NIST traceable recertification tool, 1.0 µS
3-2850.101-2	159 001 393	Plug-in NIST traceable recertification tool, 2.5 µS
3-2850.101-3	159 001 394	Plug-in NIST traceable recertification tool, 10.0 µS
3-2850.101-4	159 001 395	Plug-in NIST traceable recertification tool, 18.2 MΩ
3-2850.101-5	159 001 396	Plug-in NIST traceable recertification tool, 10.0 MΩ

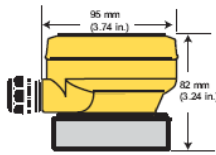

3-2850-61
3-2850-62
3-2850-63
Electronics w/Universal adapter

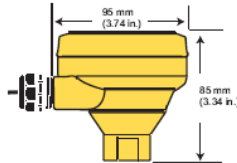

3-2850-51
3-2850-52
Electronics w/¼ in. adapter

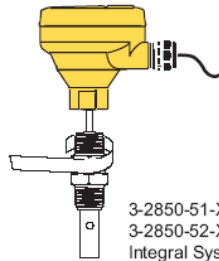

3-2850-51-XX
3-2850-52-XX
Integral System



3-2850.101-1 NIST traceable recertification tool, 1.0 µS