

# Signet 2850 Conductivity/Resistivity Sensor



## Features

- Integral mount systems for quick and easy installation
- Compact design for maximum installation flexibility
- Digital (S<sup>3</sup>L) interface or two-wire 4 to 20 mA output
- EasyCal with automatic test solution recognition

## Electronics and Integral Systems

(S<sup>3</sup>L) output version allows for up to six sensor inputs directly into the Signet 8900 Multi-Parameter Controller. The two-wire 4 to 20 mA output is available with eight 4 to 20 mA output ranges for each electrode cell constant. Additionally, each range can be inverted and are field selectable by the user.

All 2850 units are built with NEMA 4X/IP 65 enclosures which allow wiring connections with long cable runs of up to 1,000 feet (305 m). EasyCal is a standard feature that automatically recognizes conductivity test solution values for simple field calibration. A calibration tool is available for validation of the sensor electronics according to USP requirements.

Universal Mount

Threaded J-Box

## System Overview

In-Line Sensor Installation				Submersible Installation	
Panel Mount Signet 8900 Instrument (sold separately)	4 to 20 mA Input Programmable Logic Controller	Panel Mount Signet 8900 Instrument (sold separately)	4 to 20 mA Input Programmable Logic Controller	Panel Mount Signet 8900 Instrument (sold separately)	4 to 20 mA Input Programmable Logic Controller
Signet 2850 Conductivity System		Signet 2850 Universal Mount		Signet 2850 Universal Mount or Threaded J-Box	
		Signet 2819-2823 or 2839-2842 Conductivity Electrode (sold separately)			
Fittings (3/4 in. NPT or ISO) - Customer supplied					

## Description

The Signet 2850 Conductivity/Resistivity Sensor Electronics are available in various configurations for maximum installation flexibility. The universal mount version is for pipe, wall, or tank mounting and enables single or dual (digital versions only) inputs using any standard Signet conductivity / resistivity sensor. The threaded j-box version can be used with these same Signet sensors for submersible sensor mounting. It is also available as a combined

integral system configuration for in-line mounting and includes a conductivity electrode in a choice of 0.01, 0.1, 1.0, or 10.0 cm<sup>-1</sup> cell constants. The 2850 is ideal for applications with a conductivity range of 0.055 to 200,000 µS or a resistivity range of 100 MΩ to 10 kΩ.

All 2850 units are available with a choice of two outputs, digital (S<sup>3</sup>L)\* or 4 to 20 mA. The digital

- **Dual channel unit available for low cost installation with Signet 8900 Multi-Parameter Controller**

- **For use with ALL Signet conductivity electrodes**

### **Applications**

- **Water Treatment & Water Quality Monitoring**
- **Reverse Osmosis**
- **Deionization**
- **Demineralizer, Regeneration & Rinse**
- **Scrubber, Cooling tower and Boiler Protection**
- **Aquatic Animal Life Support Systems**



\* Signet Sensor Serial Link (S<sup>3</sup>L) is a proprietary digital signal that allows connection of up to 6 Signet pH, ORP, temperature, pressure, conductivity, resistivity and flow sensors directly into the 8900 multi-parameter and multi-channel instrument.

# +GF+

## Dimensions

### 2850-5X threaded J-Box

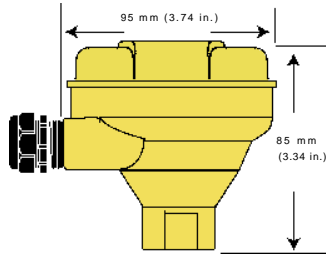

### 2850-6X Universal Mount Systems

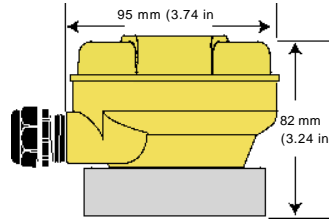

### Conductivity Sensor Dimensions

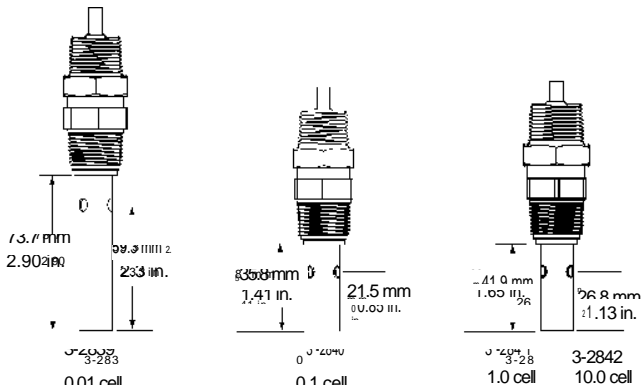

### 2850-5X-XX Integral Mount Systems

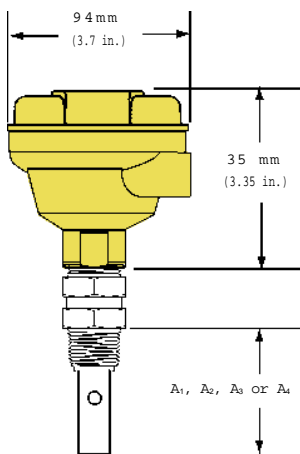

- A<sub>1</sub> (3-2839) = 73mm (2.88 in.)
- A<sub>2</sub> (3-2840) = 35mm (1.38 in.)
- A<sub>3</sub> (3-2841) = 41.3mm (1.63 in.)
- A<sub>4</sub> (3-2842) = 41.3mm (1.63 in.)

## Specifications:

### 2850 Sensor Electronics

#### General

Compatible Electrodes: All Signet models with PT-1000 RTD

#### Materials:

- Threaded j-box for Integral mount: PBT
- Universal/Remote mount: PBT, CPVC

Temperature Compensation: PT-1000 RTD

Easy-Cal: Automatic recognition of the following conductivity values:

- 146.93  $\mu$ S, 1408.8  $\mu$ S, 12856  $\mu$ S (@25°C) (Test solutions Per ASTM D1125-95)
- 10  $\mu$ S, 100  $\mu$ S, 200  $\mu$ S, 500  $\mu$ S, 1000  $\mu$ S, 5000  $\mu$ S, 10,000  $\mu$ S, 50,000  $\mu$ S, 100,000  $\mu$ S (@25°C) (Standard test solutions)

#### Electrical

Power:

- 12 to 24 VDC for 4 to 20 mA output
- 5 VDC +/-5% regulated, 3.0 mA max for Digital (S<sup>3</sup>L) output (Reverse polarity and short circuit protected)

Digital (S<sup>3</sup>L) Output: Serial ASCII, TTL level 9600 bps

- Accuracy: Conductivity:  $\pm 2\%$  of reading  
Temperature:  $\pm 0.5^\circ\text{C}$
- Resolution: Conductivity: 0.1% of reading  
Temperature:  $< 0.2^\circ\text{C}$
- Update Rate:  
Single channel models:  $< 600$  ms  
Dual channel models:  $< 1200$  ms

### 2839-2842 Electrodes (Integral 2850 Systems only)

#### General

Range:

- 2839: 0.010 to 100 $\mu$ S (10M $\Omega$  to 100K $\Omega$ ) (0.02 to 50 ppm)
- 2840: 1 to 1,000 $\mu$ S (1 M $\Omega$  to 1K $\Omega$ ) (0.5 to 500 ppm)
- 2841: 10 to 10,000 $\mu$ S (5 to 5,000 ppm)
- 2842: 100 to 200,000 $\mu$ S (100,000 ppm)  
Process connection: 3/4 in. NPT or ISO 7/1 -R3/4

Accuracy:  $\pm 2\%$  of cell constant value (standard). Cell constants can be traceable to NIST and certified to within  $\pm 1\%$  of value (contact factory)

Temperature Element: PT-1000

#### Electrical (continued):

Available data via Digital (S<sup>3</sup>L) Output:

- Raw conductivity
  - Calibrated conductivity
  - Calibrated temperature-compensated conductivity
  - Temperature
- Error Indication: Open input and out of range diagnostics for temperature or internal electronic error.

Current Output:

- Field-selectable ranges
- Factory set Span:  
0.01 cell (2819, 2839):  
4 to 20 mA = 0 to 100  $\mu$ S  
0.10 cell (2820, 2840):  
4 to 20 mA = 0 to 1000  $\mu$ S  
1.0 cell (2821, 2841):  
4 to 20 mA = 0 to 10,000  $\mu$ S  
10.0 cell (2822, 2842):  
4 to 20 mA = 0 to 200,000  $\mu$ S  
20.0 cell (2823):  
4 to 20 mA = 0 to 400,000  $\mu$ S
- Max. Loop Resistance:  
50  $\Omega$  @ 12 VDC  
325  $\Omega$  @ 18 VDC  
600  $\Omega$  @ 24 VDC
- Accuracy:  $\pm 2\%$  of output span
- Resolution: 7  $\mu$ A
- Update Rate:  $< 600$  ms
- Error Indication: 22 mA
- Pure Water Compensation: When using 0.01-cm cell and raw conductivity value  $< 0.5$   $\mu$ S, the 2850 auto-switches to compensate for non-linear temperature effects found in this low conductivity (high resistivity) range

Temp. response,  $\tau$ :

- 5 sec. (0.01 cell)
  - 10 sec. (0.10 cell)
  - 20 sec. (1.0 cell)
  - 30 sec. (10.0 cell)
- Temp. accuracy:  $\pm 0.5^\circ\text{C}$  ( $\pm 0.9^\circ\text{F}$ )

#### Wetted Materials

Internal O-ring (2841 and 2842): FPM  
Insulator material: PEEK<sup>TM</sup>  
Electrode material: 316SS  
Threaded process connection: PEEK<sup>TM</sup>

#### Max. Pressure/Temperature Ratings

Operating temperature/pressure:

- $-10^\circ\text{C}$  to  $100^\circ\text{C}$  @ 6.9 bar (14°F to 212°F @ 100psi)
- $-10^\circ\text{C}$  to  $131^\circ\text{C}$  @ 2.76 bar (14°F to 268°F @ 40 psi)

Storage Temperature

#### Shipping weight:

- Threaded j-box: 0.75 kg (1.75 lb.)
- Universal mount: 0.75 kg (1.75 lb.)

#### Standards and Approvals

- NEMA 4X/IP65
- CE
- Immunity: EN61326-1
- Emissions: EN5501 1 Class B
- Manufactured under ISO 9001 and ISO 14001

#### Shipping Weight:

- 2839: 0.34 kg (0.74 lb)
- 2840, 2841, 2842: 0.30 kg (0.66 lb)

-20°C to 131°C (-4°F to 268°F)

# +GF+

## Wiring

### 4 to 20 mA Output version

- Maximum length of 4 to 20 mA loop is 300 meters (1000 ft.)

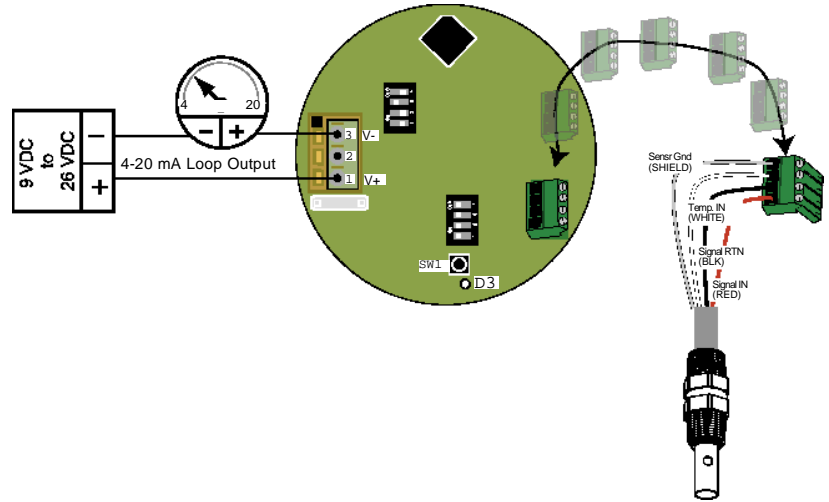

### Digital Output (S<sup>3</sup>L) version

- The digital output is compatible with the Signet 8900 Multi-Parameter Controller.
- Maximum cable length between 2850 and 8900 is determined by various factors and typically cannot exceed 457m (1500 ft.)

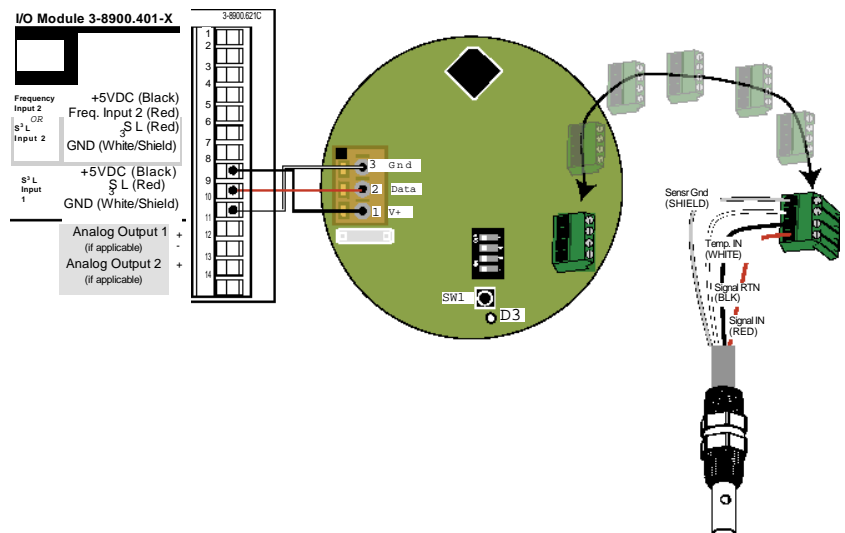

### Dual Digital Output (S<sup>3</sup>L) version

- Dual channel input is available on digital models only.
- Sensors may be the same or different cell constants.

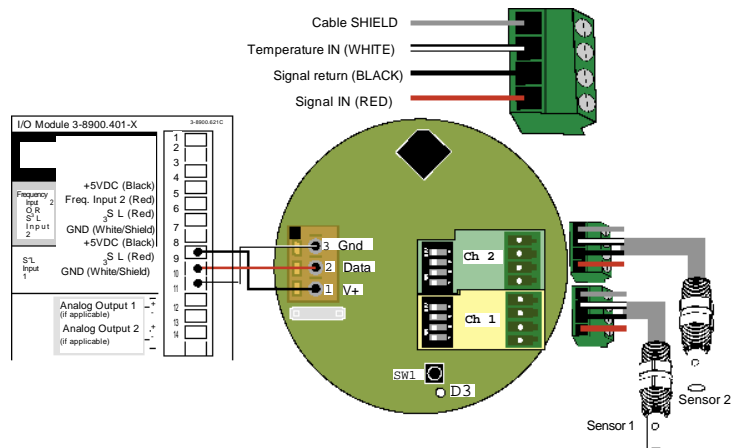

## Installation

- Position the electrode to avoid entrapment of air bubbles.
- The preferred installation for in-line applications directs flow straight into the electrode.
- If the electrode is mounted vertically in a tee, do not recess the orifices inside the tee. Mounting the sensor upside down may help prevent air entrapment.
- An oversized tee or flow cell may be helpful for inline installations.

### In-line sensor mounting with remote/universal mount 2850

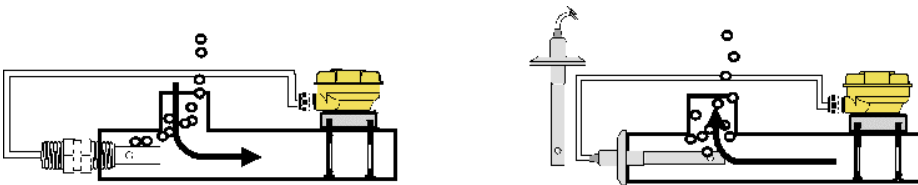

### In-line integral system mounting

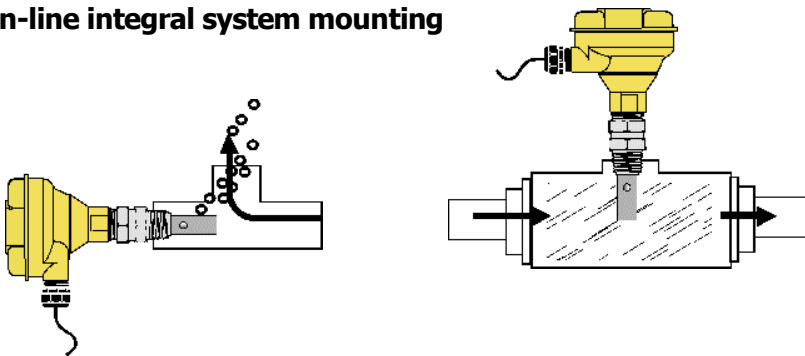

### Submersible sensor mounting

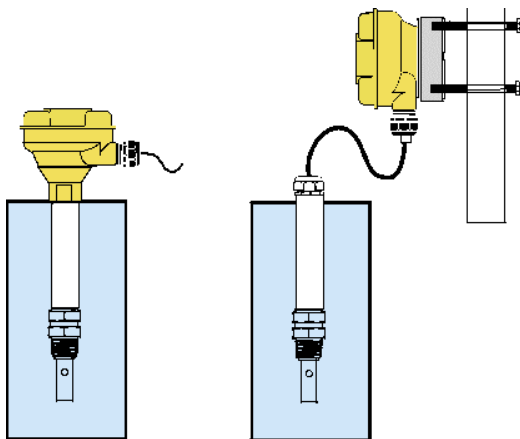

Using the 2850-5X

Using the 2850-6X



## Operating Range Chart

The 2850 is capable of measuring conductivity and resistivity values over a wide range. Below is a chart of Signet Conductivity/Resistivity electrodes (listed in each range box) that is recommended for the specified measurement range.

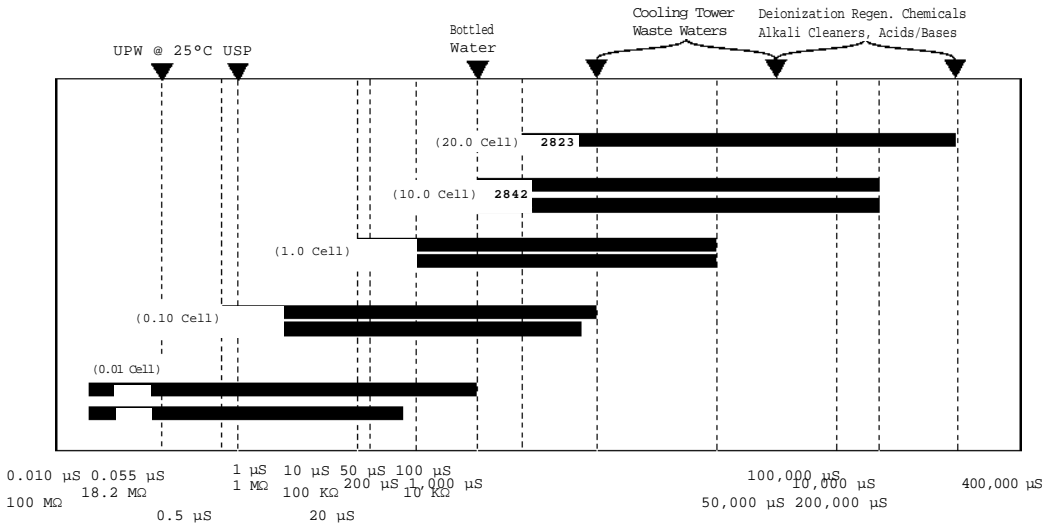

## Field Selectable Ranges for 4 to 20 mA Operation

The chart below indicates the field selectable ranges in which the 2850 sensor electronics can be set via internal switches. All ranges can be inverted if required. Signet Models listed below are compatible Conductivity/Resistivity electrodes.

0.01 Cell	0.10 Cell	1.0 cell	10.0 Cell	20.0 Cell
Signet Model 2819 or 2839	Signet Model 2820 or 2840	Signet Model 2821 or 2841	Signet Model 2822 or 2842	Signet Model 2843
<b>10 to 20 M<math>\Omega</math></b>	0 to 2 $\mu\text{S}$	0 to 20 $\mu\text{S}$	0 to 200 $\mu\text{S}$	0 to 400 $\mu\text{S}$
<b>2 to 10 M<math>\Omega</math></b>	0 to 5 $\mu\text{S}$	0 to 50 $\mu\text{S}$	0 to 500 $\mu\text{S}$	0 to 1,000 $\mu\text{S}$
<b>0 to 2 M<math>\Omega</math></b>	0 to 10 $\mu\text{S}$	0 to 100 $\mu\text{S}$	0 to 1,000 $\mu\text{S}$	0 to 2,000 $\mu\text{S}$
0 to 1 M $\Omega$	0 to 50 $\mu\text{S}$	0 to 500 $\mu\text{S}$	0 to 5,000 $\mu\text{S}$	0 to 10,000 $\mu\text{S}$
0 to 5 M $\Omega$	0 to 100 $\mu\text{S}$	0 to 1000 $\mu\text{S}$	0 to 10,000 $\mu\text{S}$	0 to 20,000 $\mu\text{S}$
0 to 10 M $\Omega$	0 to 200 $\mu\text{S}$	0 to 2000 $\mu\text{S}$	0 to 50,000 $\mu\text{S}$	0 to 100,000 $\mu\text{S}$
0 to 50 M $\Omega$	0 to 500 $\mu\text{S}$	0 to 5,000 $\mu\text{S}$	0 to 100,000 $\mu\text{S}$	0 to 200,000 $\mu\text{S}$
0 to 100 M $\Omega$	0 to 1,000 $\mu\text{S}$	0 to 10,000 $\mu\text{S}$	0 to 200,000 $\mu\text{S}$	0 to 400,000 $\mu\text{S}$

The 4 to 20 output ranges shown in this chart can be inverted using the internal switch  
**Resistivity Ranges are in BOLD**

## Electronic Certification/Calibration

Signet offers conductivity simulators with  $\pm 0.1\%$  precision (accuracy) in five different values: 1.0  $\mu\text{S}$ , 2.5  $\mu\text{S}$ , 10.0  $\mu\text{S}$ , 18.2 M $\Omega$ , 10.0 M $\Omega$ . These are all temperature compensated to 25°C and enable the user to validate the performance of the electronics independently of the electrode. This requirement is defined by ASTM D 1125-95 (Standard Test Methods for Electrical Conductivity and Resistivity of Water) which is commonly used for USP 24 applications.

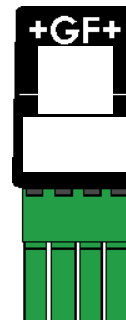

## Ordering Information



### 2850 Integral Systems

Use this ordering matrix when an integral 2850 system is desired (uses 2839-2842 series electrodes). Integral systems are shipped with a sensor and 2850 combined. Other 2850 systems are available with Signet 2819 to 2823 electrodes upon request.

Integral Mount System (includes Sensor Electronics and electrodes)			
<b>3-2850</b>	Conductivity and Resistivity Sensor Electronics		
	Output Type		
	<b>-51</b>	Digital (S <sup>3</sup> L) output with EasyCal	
	<b>-52</b>	4 to 20mA output with EasyCal	
		Sensor Option	
	<b>-39</b>	2839 Electrode, 0.01 cell	
	<b>-40</b>	2840 Electrode, 0.1 cell	
	<b>-41</b>	2841 Electrode, 1.0 cell	
	<b>-42</b>	2842 Electrode, 10.0 cell	
		Process threaded connection types	
	<b>D</b>	ISO threads	
	<b>-</b>	NPT threads	
<b>3-2850</b>	<b>-52</b>	<b>-39</b>	<b>Example Part Number</b>

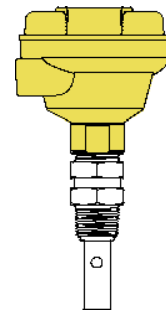

Integral System includes the 2850 sensor electronics and a choice of Conductivity/Resistivity electrode.

### 2850 Sensor Electronics

Use this ordering matrix when remote sensor mounting is desired. The 2850-5X and 2850-6X are compatible with ALL Signet conductivity electrodes.

Sensor Part Number			
<b>3-2850</b>	Conductivity Sensor Electronics with 4 to 20 mA or digital output		
	Mounting configurations		
	<b>-5</b>	3/4 inch threaded j-box for standpipe mounting, single input only	
	<b>-6</b>	Universal Mount Junction Box for remote mount, single or dual input	
		Output choices	
	<b>1</b>	one input/one Digital (S <sup>3</sup> L) output	
	<b>2</b>	one input/one 4 to 20 mA output	
	<b>3</b>	two inputs/two Digital (S <sup>3</sup> L) outputs (available for -6X versions only)	
<b>3-2850</b>	<b>-5</b>	<b>2</b>	<b>Example Part Number</b>

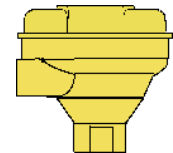

-5X threaded J-Box

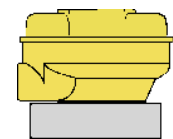

-6X Universal/Remote Mount

Mfr. Part No.	Code	Mfr. Part No.	Code
3-2850-5 1	<b>159 001 398</b>	3-2850-52-40	<b>159 001 348</b>
3-2850-51-39	<b>159 001 339</b>	3-2850-52-41	<b>159 001 349</b>
3-2850-51 -40	<b>159 001 340</b>	3-2850-52-42	<b>159 001 350</b>
3-2850-5 1 -41	<b>159 001 341</b>	3-2850-52-39D	<b>159 001 351</b>
3-2850-51 -42	<b>159 001 342</b>	3-2850-52-40D	<b>159 001 352</b>
3-2850-51-39D	<b>159 001 343</b>	3-2850-52-41 D	<b>159 001 353</b>
3-2850-51-40D	<b>159 001 344</b>	3-2850-52-42D	<b>159 001 354</b>
3-2850-5 1 -41 D	<b>159 001 345</b>	3-2850-6 1	<b>159 001 400</b>
3-2850-51-42D	<b>159 001 346</b>	3-2850-62	<b>159 001 401</b>
3-2850-52	<b>159 001 399</b>	3-2850-63	<b>159 001 402</b>
3-2850-52-39	<b>159 001 347</b>		



## Accessories and Replacement Parts

Mfr. Part No.	Code	Description
3-2839-3	<b>159 001 355</b>	Electrode - 0.01 $\mu\text{S}/\text{cm}$ , 6 in. cable, NPT
3-2839-3D	<b>159 001 359</b>	Electrode - 0.01 $\mu\text{S}/\text{cm}$ , 6 in. cable, ISO
3-2840-3	<b>159 001 356</b>	Electrode - 0.1 $\mu\text{S}/\text{cm}$ , 6 in. cable, NPT
3-2840-3D	<b>159 001 360</b>	Electrode - 0.1 $\mu\text{S}/\text{cm}$ , 6 in. cable, ISO
3-2841-3	<b>159 001 357</b>	Electrode - 1.0 $\mu\text{S}/\text{cm}$ , 6 in. cable, NPT
3-2841-3D	<b>159 001 361</b>	Electrode - 1.0 $\mu\text{S}/\text{cm}$ , 6 in. cable, ISO
3-2842-3	<b>159 001 358</b>	Electrode - 10.0 $\mu\text{S}/\text{cm}$ , 6 in. cable, NPT
3-2842-3D	<b>159 001 362</b>	Electrode - 10.0 $\mu\text{S}/\text{cm}$ , 6 in. cable, ISO
3-2850-51	<b>159 001 398</b>	Sensor Electronics, digital (S <sup>3</sup> L) output
3-2850-52	<b>159 001 399</b>	Sensor Electronics, 4 to 20mA output
3-2850.101-1	<b>159 001 392</b>	Plug-in NIST traceable recertification tool, 1.0 $\mu\text{S}$ simulated
3-2850.101-2	<b>159 001 393</b>	Plug-in NIST traceable recertification tool, 2.5 $\mu\text{S}$ simulated
3-2850.101-3	<b>159 001 394</b>	Plug-in NIST traceable recertification tool, 10.0 $\mu\text{S}$ simulated
3-2850.101-4	<b>159 001 395</b>	Plug-in NIST traceable recertification tool, 18.2 M $\Omega$ simulated
3-2850.101-5	<b>159 001 396</b>	Plug-in NIST traceable recertification tool, 10.0M $\Omega$ simulated