

TEMPERATURE TRANSMITTER (HART communication, intrinsically safe/flameproof)

MODEL

FRC

BEFORE USE

Thank you very much for your purchase of the Fuji FRC Transmitter. Before use, please check contents of the package you received as outlined below.

If you have any problems or questions with the product, please contact Fuji's Sales Office or representatives.

■ PACKAGE INCLUDES:

Transmitter	(1)
Short bar	(1)
Outdoor enclosure (FRC1)	(1)
Mounting screws (FRC1)	(4)
2-inch pipe mounting bracket (FRC1)	(1) set

■ MODEL NO.

Check that model No. described on the specification label is exactly what you ordered.

■ SAFETY PRECAUTIONS

This manual describes necessary points of caution when you use this product, including installation, connection and basic maintenance procedures.

Information that potentially raises safety issues is indicated by a warning symbol (⚠). Please refer to the following safety messages before performing an operation preceded by this symbol.

⚠ POINTS OF CAUTION

The following are general precautions when using this unit. The safety features and precautions specific to the hazardous locations are explained in Page 10.

■ POWER INPUT RATING

- Use a stable power source. The FRC restarts with a power interruption for longer than 1 millisecond.

■ ENVIRONMENT

- The model FRC0 is for indoor use.
- When heavy dust or metal particles are present in the air, install the unit inside an outdoor enclosure.
- Environmental (non-hazardous location) temperature must be within -40 to +85°C (-40 to 185°F) in order to ensure adequate life span and operation.
- For installing the FRC0 in an environment with a high relative humidity exceeding 0 to 95% RH or in a condensing atmosphere, install the unit inside an outdoor enclosure.
- Do not install the unit where it is subjected to continuous vibration. Do not subject the unit to physical impact.
- For use in a hazardous location, be sure that the environmental temperature is within the temperature class required for the area.

■ WIRING

- Do not install cables (input and output) close to noise sources (relay drive cable, high frequency line, etc.).
- Do not bind the unit's cables together with cables where high noise levels are present. Do not install them in the same duct.

■ AND

- The unit is designed to function as soon as power is supplied, however, a warm up for 10 minutes is required for satisfying complete performance described in the data sheet.

COMPONENT IDENTIFICATION

Figure 1. FRC0 exploded view and component identification

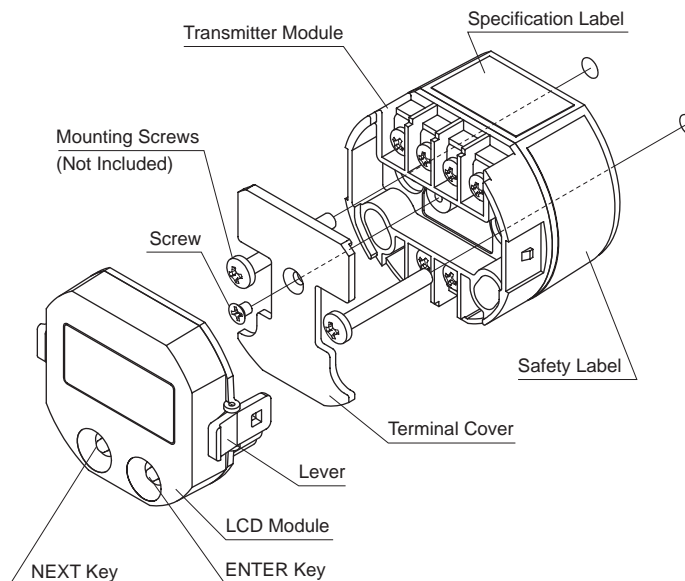
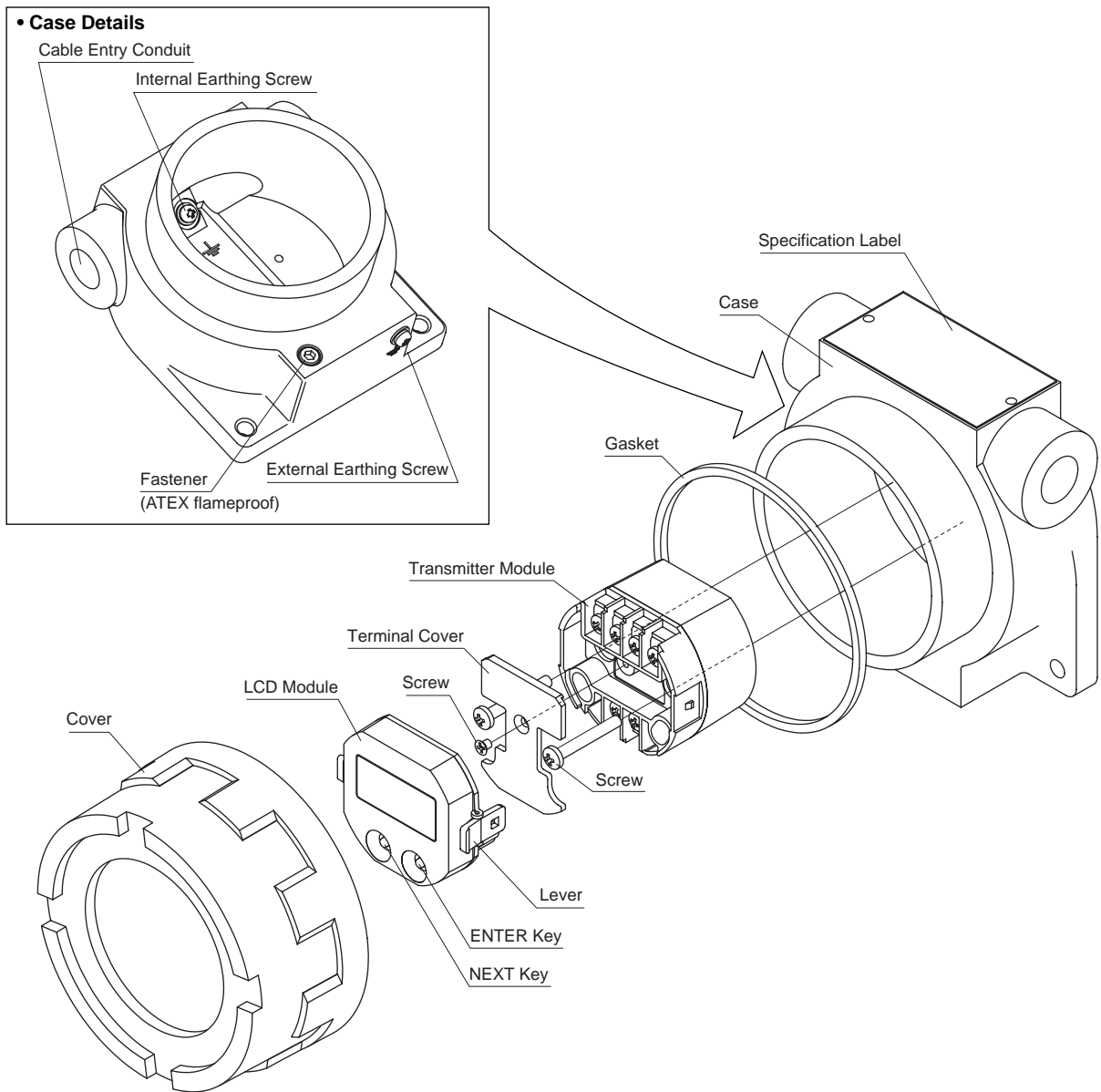

Figure 2. FRC1 exploded view component identification



EXTERNAL DIMENSIONS mm (inch)

Figure 3. FRC0 external dimensions

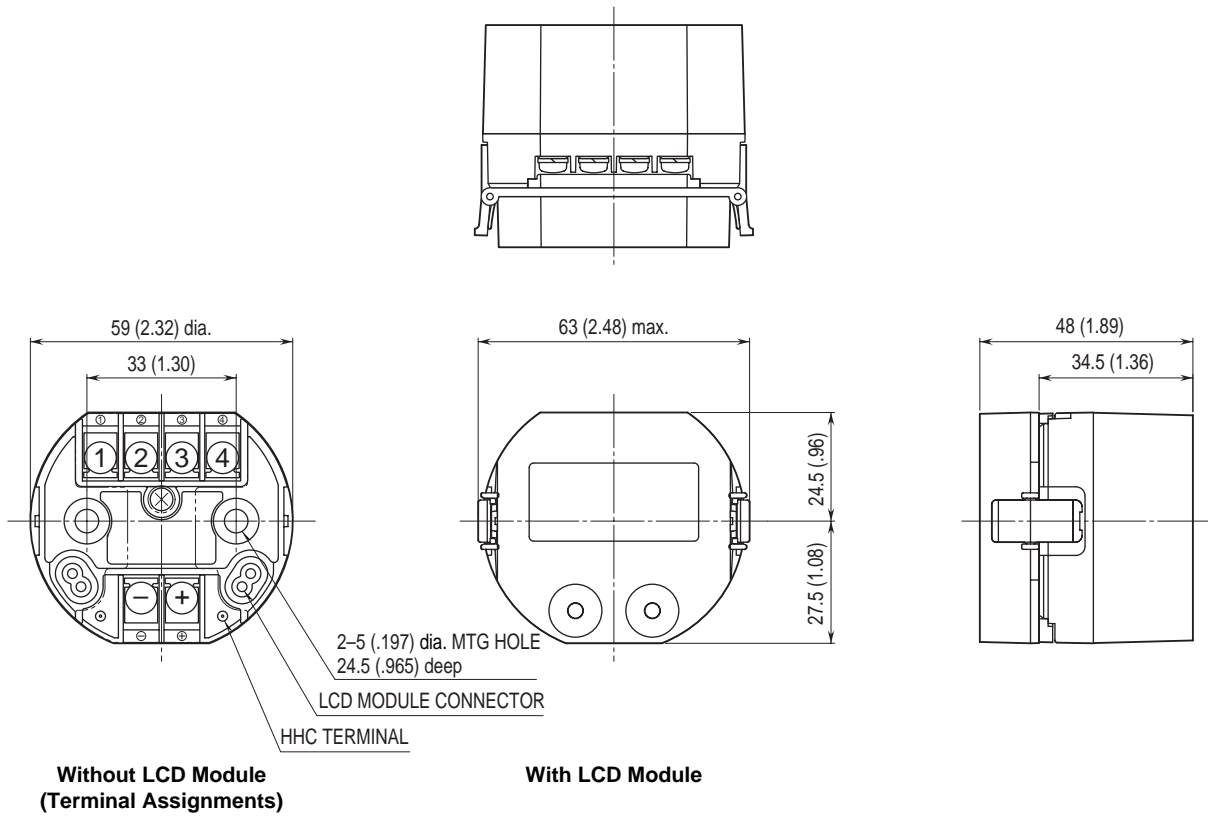
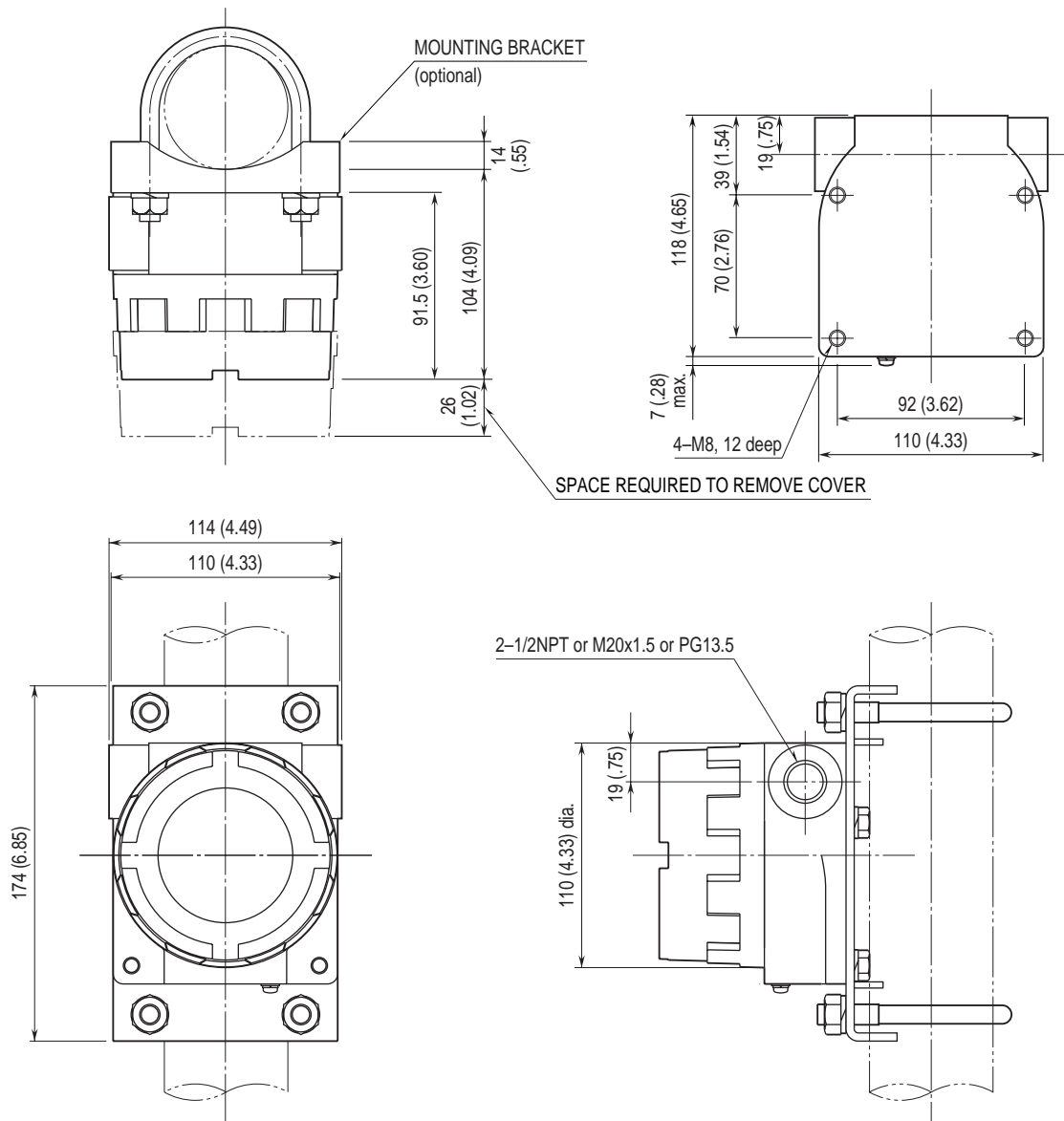

Figure 4. FRC1 external dimensions



INSTALLATION

■ LCD MODULE

- For attaching the LCD module, hold the levers at the side and push into the connectors on top of the transmitter module.
- When removing the module, hold the levers in the same manner and pull.

■ WALL MOUNTING

Refer to Figures 1 and 3.

■ OUTDOOR INSTALLATION

For mounting the transmitter module inside the outdoor enclosure, refer to Figure 2.

■ MOUNTING THE ENCLOSURE ON A PIPE

See Figures 5 below.

Figure 5. Pipe mounting

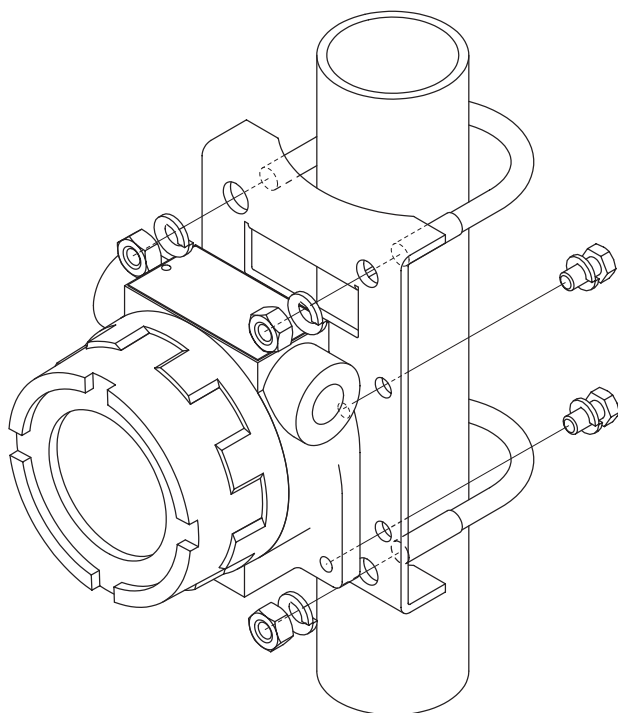

■ MOUNTING THE ENCLOSURE ON A WALL

See Figures 4 and 6 (below).

Figure 6. Wall mounting

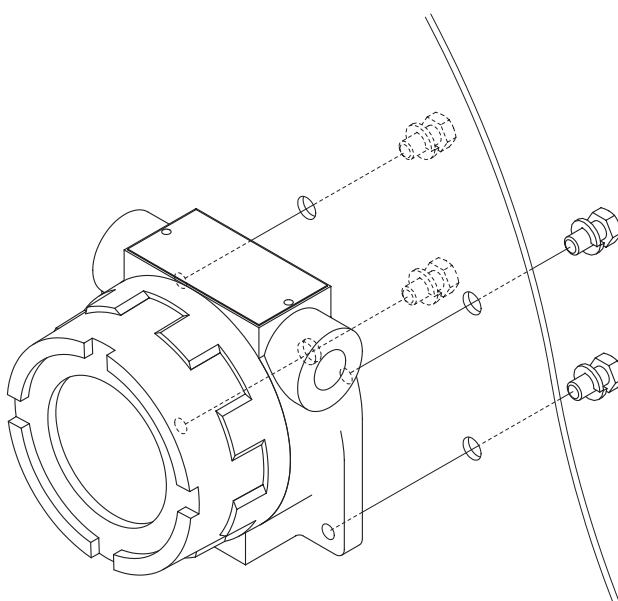

TERMINAL CONNECTIONS

Connect the unit as in the diagram below. For use in a hazardous location, refer to "Installation Diagram" attached at the end of this manual.

Figure 7. Connection diagram

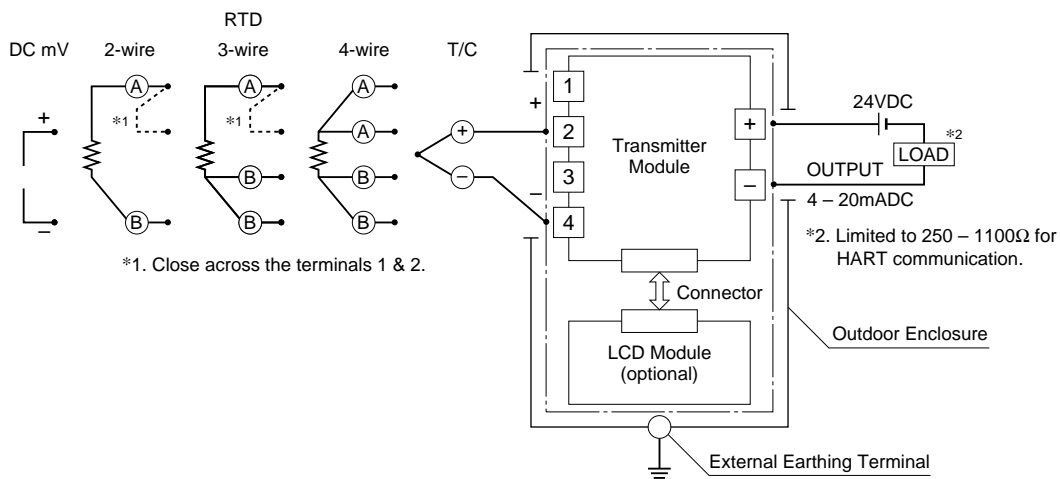

CHECKING

⚠ Warning! Whenever you need to measure voltage across the terminals or apply a simulated input signal to the terminals, make sure that there is no danger of explosion in the atmosphere.

- 1) Terminal wiring: Check that all cables are correctly connected according to the connection diagram.
- 2) Input type and range setting: Check that the input type and range are correctly set.
- 3) Input: Check that the input signal is within 0 – 100% of the full-scale.

If the thermocouple/RTD or its extension wires are broken, the output goes over 100% (below 0% with downscale) due to the burnout function. Check leadwires in such a case.

- 4) Output: Check that the load is within the permissible limit including wiring resistance.

$$\text{Load Resistance } (\Omega) = \frac{\text{Supply Voltage (V)} - 12 \text{ (V)}}{0.024 \text{ (A)}}$$

(including leadwire resistance)

ADJUSTMENT PROCEDURE

■ USING THE HART COMMUNICATION

Refer to the HART Setup Manual (EM-7451-FIC-B). For operating an HHC (Hand-Held Communicator), refer to its instruction manual.

■ USING THE LCD MODULE

Figure 8 shows the display panel configuration of the LCD module, and Figure 9 shows the basic operation flow chart for programming the transmitter.

• How to Input Numerical Figures on the LCD

Numerical figures (numbers) can be set by combining NEXT and ENTER key operations.

Pressing the NEXT key increases the value from 0 to 9 and back to 0 again. Pressing the ENTER key when a desired value is shown sets the value and then moves to the next less significant digit. Pressing the ENTER key at the least significant digit completes the input.

For the most significant digit, numbers change from 0, 1, 2 through 9, then -0, -1, -2, through -9, and then back to 0.

• Basic Operation

When the power supply is turned on, the "RUN" indicator on the LCD module flashes until communication with the transmitter module is established. Once established, the "RUN" indicator remains on.

The LCD starts up in the Display Mode.

The upper (first) row on the display indicates numerical figures, and the lower (second) row indicates messages.

Pressing the NEXT key one or more times switches the module between the Configuration Mode, Calibration Mode and Display Mode.

Pressing the ENTER key in the Configuration Mode or Calibration Mode calls up the first programming item (step). In this state, every time the NEXT key is pressed, the next item and current setting is displayed until it returns to the Display Mode after the last programming item.

Whenever the type/value within a particular programming step can be changed, "PGM" is shown on the LCD. When each step is complete, the "PGM" indicator is turned off.

• LCD Panel Indication in the Display Mode

"Burnout State" includes not only a temperature sensor's wire breakdown but also an overrange input outside the physically set range for thermocouples or RTDs.

"Saturation State" is when an overrange input is applied outside the physically set range and proportional to the output smaller than 3.8mA or exceeding 21.6mA.

Normal State	
Top row	Numerical figures
Bottom row	HART address*1
BO	OFF
ERR	OFF
asterisk	OFF
Eng. unit	ON*1
Saturation State	
Top row	Numerical figures
Bottom row	HART address*1
BO	OFF
ERR	OFF
asterisk	ON
Eng. unit	ON*1
Burnout State	
Top row	Blank
Bottom row	HART address*1
BO	ON
ERR	OFF
asterisk	ON
Eng. unit	ON*1

*1. When an appropriate unit symbol is not available among the selections on the LCD, the bottom row indicates the unit and HART address alternately.

• Programming Procedure in the Configuration Mode

1) Input Type (SelectInput)

First choose the input type. Pressing the NEXT key one or more times switches between each of the available input types. Press ENTER to set a desired input type.

When Thermocouple, RTD or potentiometer is selected, the display goes to the sensor type list. Use the NEXT and ENTER keys to choose a sensor type.

See Table 1 through 3 for available input types.

Table 1. Input types

Input type	LCD bottom row
Thermocouple	TC
2-wire RTD	2-RTD
3-wire RTD	3-RTD
4-wire RTD	4-RTD
mV	MV

Table 2. Thermocouples

Sensor type	Bottom row	Sensor type	Bottom row
B	TC/B	T	TC/T
E	TC/E	W	TC/W5
J	TC/J	U	TC/U
K	TC/K	L	TC/L
N	TC/N	P	TC/P
R	TC/R	PR	TC/PR
S	TC/S		

Table 3. RTDs

RTD type	Top row	Bottom row*2
IEC Pt 100	100	n-IPT

*2. n = 2 : 2-wire, 3 : 3-wire, 4 : 4-wire

2) Temperature Unit (SelectUnit)

For a thermocouple or RTD input, the Temperature Unit can be specified.

At the initial state, the LCD shows the current setting. Pressing the NEXT key one or more times switches between the available temperature units. Stop when a desired selection is displayed, and press ENTER.

For mV, resistance and potentiometer inputs, settings other than "mV", "Ω" and "%" respectively cannot be selected.

See Table 4.

Table 4. Temperature units

Temperature unit	LCD bottom row
Degree Celcius	DEG C
Degree Fahrenheit	DEG F
Degree Rankine	DEG R
Degree Kelvin	DEG K

3) Burnout (BurnoutDirection)

At the initial state, the LCD shows the current setting. Pressing the NEXT key one or more times switches between "High" (upscale), "Low" (downscale), and "Off" (no burnout). Stop when a desired selection is displayed, and press ENTER.

4) Lower Range Input (InputLowerRange)

Lower and Upper Input ranges can be specified.

At the initial state, the LCD shows the current 0%* setting.

Values are indicated in the selected temperature unit (T/C and RTD) or mV (DC mV).

Set an actual value on the top row of the LCD.

*For potentiometer input, enter the percentage of the total resistance for both the lower and upper ranges.

5) Upper Range Input (InputUpperRange)

Refer to the Lower Range Input.

6) Display Item (SelectDisplay)

Specifies the item to be monitored on the LCD in the Display Mode.

At the initial state, the LCD shows the current setting.

Pressing the NEXT key one or more times switches between available selection items. Stop when a desired selection is displayed, and press ENTER.

See Table 5 for available display items.

Table 5. Display items

Item	Bottom row
Input (unit as selected in SelectUnit)	I ENG
Input in %	I PER
Output in %	O PER
Output in mA	O ENG
Cold junction temperature (T/C only)	CJM

• Programming Procedure in the Calibration Mode

1) Output Zero Adjustment (TrimOutput4mA)

Used to fine tune 4mA output.

At the initial state, the unit outputs 4mA regardless of actual input value.

Set an actual measured value on the top row of the LCD.

2) Output Span Adjustment (TrimOutput20mA)

Used to fine tune 20mA output.

At the initial state, the unit outputs 20mA regardless of actual input value.

Set an actual measured value on the top row of the LCD.

Figure 8. LCD display panel configuration

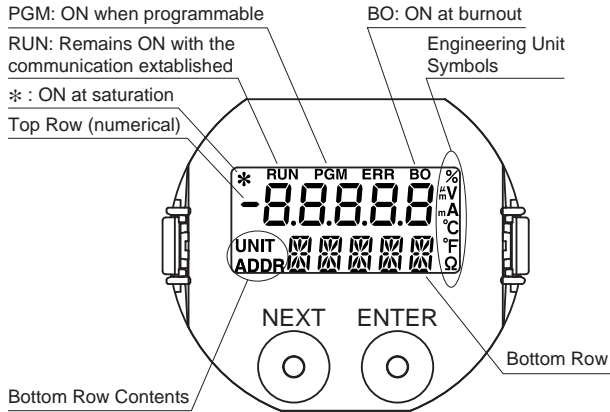

•Key Operations in Entering Numerical Value

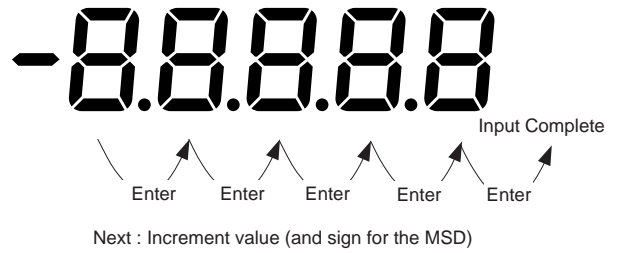

Unexplained symbols are unused for the B6U and B6U-B.

Figure 9. Programming operation flowchart

