

# TEMPERATURE TRANSMITTER

## DATA SHEET

FRC

FRC is a programmable two wire temperature transmitter suitable for head or field mounting.

## FEATURES

1. Universal input:mV,V,thermocouple,RTD
2. High accuracy
3. HART communication
4. Intrinsically safe and explosion-proof approvals
5. Sensor burnout
6. A wide variety of thermocouple types
7. Programming via hand-held communicator or via PC
8. Self diagnostics
9. Input-output isolated

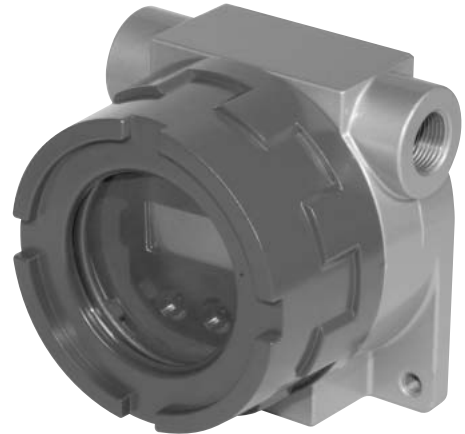

## SPECIFICATIONS

### General specifications

**Environmental protection:**

NEMA 4X,IP65

**Wiring conduit:** See code symbols.

**Electrical connection:**

M3.5 screw terminals

**Materials**

**Housing:** Die-cast aluminum (epoxy resin and urethan resin coated in layers)

Body color: silver

Cover color: blue

(Munsell 6PB3.5/10.5)

**Mounting bracket assembly:** SUS 304

**Isolation:** Input to output

**User-configurable item:**

- Input sensor type
- Number of wires (RTD)
- Input ranges
- Zero and span adjustments
- Simulated output
- HART communication mode (burst mode selectable)
- HART network mode (point-to-point or multidrop)

**Linearization:** Standard feature

**Inverted output:** User-selectable (default:no inversion)

**Cold junction compensation (thermocouple):** available

**Burnout:** Upscale,downscale or no burnout selectable (default:upscale)

**Damping time:** 0 to 30 sec.(default:0sec)

### LCD display (option)

**Features:** Indicates input signal, engineering unit and transmitter status.

**Display size:** approx. 36 x 20 mm

**Characters**

**Color:** Black

**Format:** 2 rows of 5 alphanumeric characters;

Top: 7.4 mm high

Bottom: 6.5 mm high

6 status characters,1.9 mm high

**Display range:** -99999 to 99999

**Decimal point:** Top row only; positioned between two characters

### Hart communication

**Protocol:** HART communication protocols

**Transmission speed:** 1200 bps

**Digital current:** Approx.1mA p-p when communicating

**Character format:**

1 start bit, 8 data bits, 1 odd parity bit,

1 stop bit

**Distance:** 1.5 km

**HART communication mode:**

Master-slave mode and burst mode

## Input

Input types, min. span and max. range: See Table 1.

DC mV & V: Input resistance 1MΩ minimum

Thermocouple: Burnout sensing 130nA ±10%

RTD: Wiring resistance.

Max.20Ω per wire

The input is factory set for use with RTD (3-wire) 0 to +150°C.

## Output

Default output range: 4 to 20mA DC

Zero adjustment: 3.8 to 7.2mA

Span adjustment: 12.8 to 17.6mA

Operational range: 3.8 to 21.6mA

Load resistance vs. supply voltage:

$$\text{Max. load resistance } (\Omega) = \frac{\text{Supply voltage (V)} - 12 \text{ (V)}}{0.024 \text{ (A)}}$$

(including leadwire resistance)

Note: For communication with HART, min. of 250Ω required.

## Installation

Supply voltage: 12 to 42V DC

Operating temperature :

-40 to +85°C Electronics

-30 to +80°C Display (full visibility)

Operating humidity: 0 to 95%RH (non-condensing)

Mounting: Pipe mounting or head-mounting

Dimensions: See outline diagram.

Weight: Approx.1.3 kg

## Performance

Accuracy: See Table 1.

Cold junction compensation: ≤±0.5°C (at -5 to +55°C)

Temperature coefficient (of max.span at -5 to +55°C): ±0.015%/°C

Start-up time: approx.8 sec.

Response time: ≤1 seconds (0 to 63%)with damping time set to 0 and when not communicating via HART.

Supply voltage effect:

±0.003% of span/V

Insulation resistance:

≥100MΩ with 500V DC (input to output)

Dielectric strength:

1500V AC x 1 minute

(input to output)

## Standards & Approvals

CE conformity:

ATEX Directive (94/9/EC)

EEx ia EN50020

EEx d EN50018

EMC Directive (89/336/EEC)

EMI EN61000-6-4

EMS EN61000-6-2

Safety approvals:

FM : Intrinsically safe

Class I, Div.1, Groups A, B, C and D;

T4, T5 and T6;

Class II, Div.1, Groups E, F and G;

T4, T5 and T6;

Class III, Div.1; T4, T5 and T6

(Class 3610)

Class I, Zone 0, AEx ia IIC

T4, T5 and T6;

FM : Flameproof

Class I, Div.1, Groups B, C and D;

T4, T5 and T6;

Class II, Div.1, Groups E, F and G;

T4, T5 and T6;

Class III, Div.1; T4, T5 and T6

(Class 3615)

ATEX : Intrinsically safe

II 1G, EEx ia IIC ; T4, T5 and T6

(EN50020 -1994) (KEMA)

ATEX : Flameproof

II 2G, EEx d IIC ; T4, T5 and T6

(EN50018 -2000) (KEMA)

## Related products

- PC configurator software
- HART modem\*
  - VIATOR interface
  - web site: www.mactekcorp.com
- Hand-held communicator\*

\* Consult HART Communication Foundation (HCF)

web site: www.hartcomm.org.

## CODE SYMBOLS

Digit	Description	Note	1	2	3	4	5	6	7	8	
4	<b>Case</b> None (modul only) Yes		F	R	C		0			1	
5	<b>Approvals for hazardous locations</b> None FM flameproof (*1) ATEX flameproof (*2) FM intrinsic safty (*3) ATEX intrinsic safty	Note 1 Note 2 Note 3					A	B	C	D	E
6	<b>Display</b> None LCD						0		1		
7	<b>Wiring conduit</b> None 1/2NPT M20 x 1.5 PG13.5								0	1 2 3	

Note: (\*1) Available for 7th digit code "1"

Note: (\*2) Available for 7th digit code "1","2"

Note: (\*3) Available for 7th digit code "0","1","2"

## SCOPE OF DELIVERY

Temperature transmitter, mounting bracket, instruction manual.

**Table 1**

Input type	Min. span	Max. range	Accuracy of the DC voltage					
DC mV & V	4mV	-50 to +1000mV	$\pm 0.1\%$ or $\pm 10\mu\text{V}$ , whichever is greater (F.S. input $\leq 50\text{mV}$ ) $\pm 0.1\%$ or $\pm 40\mu\text{V}$ , whichever is greater (F.S. input $\leq 200\text{mV}$ ) $\pm 0.1\%$ or $\pm 60\mu\text{V}$ , whichever is greater (F.S. input $\leq 500\text{mV}$ ) $\pm 0.1\%$ or $\pm 80\mu\text{V}$ , whichever is greater (F.S. input $> 500\text{mV}$ )					
Thermocouple	°C				°F			
	Min. span	Max. range	Conformance range	Accuracy *1	Min. span	Max. range	Conformance range	Accuracy *1
(PR)	20	0 to 1760	0 to 1760	$\pm 1.00$	36	32 to 3200	32 to 3200	$\pm 1.80$
K (CA)	20	-270 to +1370	-150 to +1370	$\pm 0.25$	36	-454 to +2498	-238 to +2498	$\pm 0.45$
E (CRC)	20	-270 to +1000	-170 to +1000	$\pm 0.20$	36	-454 to +1832	-274 to +1832	$\pm 0.36$
J (IC)	20	-210 to +1200	-180 to +1200	$\pm 0.25$	36	-346 to 2192	-292 to +2192	$\pm 0.45$
T (CC)	20	-270 to +400	-170 to +400	$\pm 0.25$	36	-454 to +752	-274 to +752	$\pm 0.45$
B (RH)	20	100 to +1820	400 to +1760	$\pm 0.75$	36	212 to +3308	752 to +3200	$\pm 1.35$
R	20	-50 to +1760	200 to 1760	$\pm 0.50$	36	-58 to 3200	392 to 3200	$\pm 0.90$
S	20	-50 to +1760	0 to 1760	$\pm 0.50$	36	-58 to +3200	32 to 3200	$\pm 0.90$
C (WRe 5-26)	20	0 to 2315	0 to 2315	$\pm 0.25$	36	32 to 4199	32 to 4199	$\pm 0.45$
N	20	-270 to +1300	-130 to +1300	$\pm 0.30$	36	-454 to +2372	-202 to +2372	$\pm 0.54$
U	20	-200 to +600	-200 to +600	$\pm 0.20$	36	-328 to +1112	-328 to +1112	$\pm 0.36$
L	20	-200 to +900	-200 to +900	$\pm 0.25$	36	-328 to +1652	-328 to +1652	$\pm 0.45$
P (Platinel II)	20	0 to +1395	0 to +1395	$\pm 0.25$	36	32 to 2543	32 to 2543	$\pm 0.45$
RTD	EXCITATION	°C			°F			
		Min. span	Max. range	Accuracy *1	Min. span	Max. range	Accuracy *1	
Pt 100 (JIS '97/DIN/IEC)	0.2mA	20	-200 to 850	$\pm 0.15$	36	-328 to 1562	$\pm 0.27$	

\*1 : Or  $\pm 0.1\%$ , whichever is greater.

\*2 : In case of using RTD, accuracy is determined by achieving zero and span calibration after wiring.

## WIRING CONNECTIONS

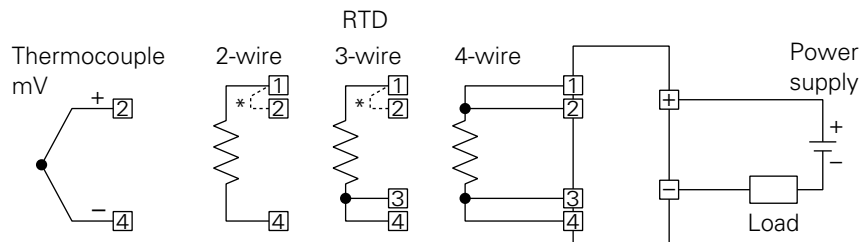

\* Close across the terminals 1 & 2.

**OUTLINE DIAGRAM (Unit:mm)**

**Model FRC1**

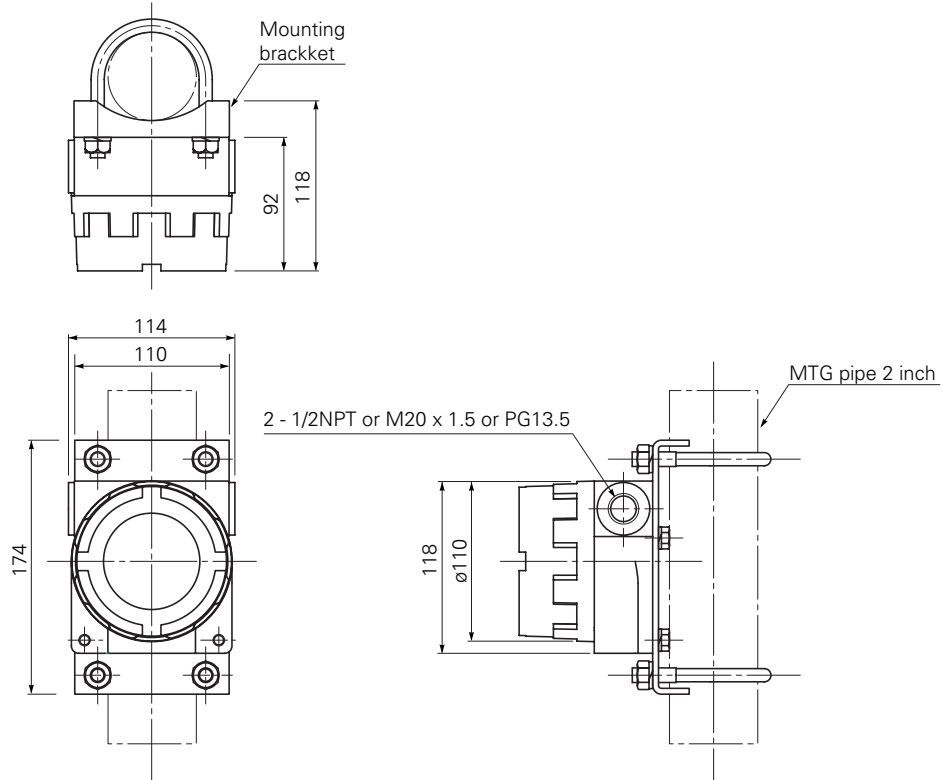

**Model FRC0**

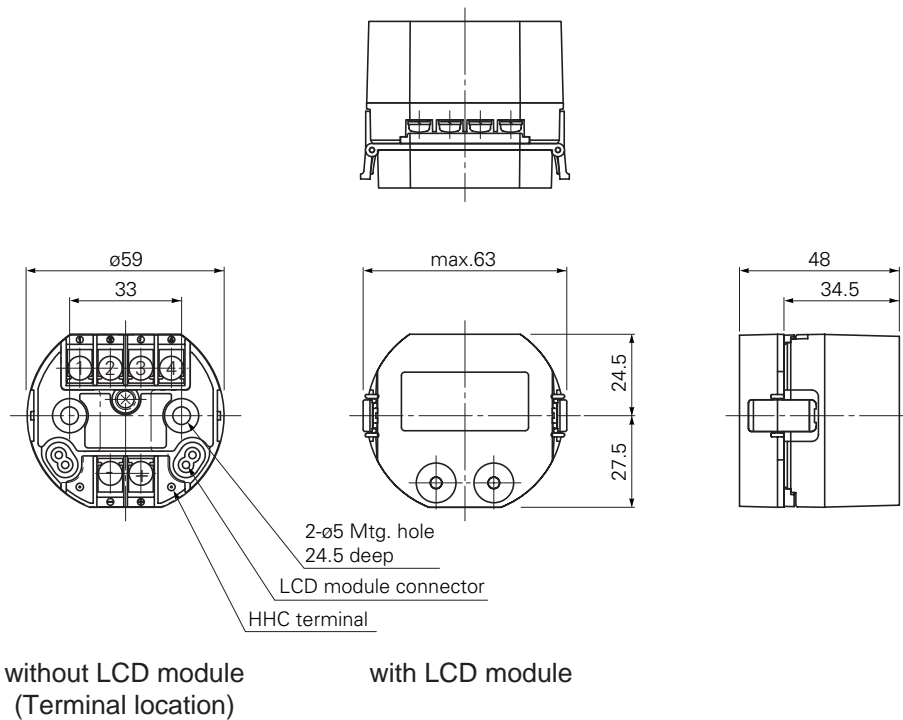

⚠ Caution on Safety

\*Before using this product, be sure to read its instruction manual in advance.

**Fuji Electric Systems Co.,Ltd.**

**Head Office**

6-17, Sanbancho, Chiyoda-ku, Tokyo 102-0075, Japan  
<http://www.fesys.co.jp/eng>

**Sales Div.**

**International Sales Dept.**

No.1, Fuji-machi, Hino-city, Tokyo, 191-8502 Japan  
 Phone: 81-42-585-6201, 6202 Fax: 81-42-585-6187  
<http://www.fic-net.jp/eng>