

FLEX-PRO™

Peristaltic Metering Pump



SERIES A3V

Operating Manual

Patents: 7,001,153 4,496,295
and other patents pending

Exclusive:



Patent No. 7,001,153



ProSeries™

by Blue-White Ind.

5300 Business Drive, Huntington Beach, CA 92649 USA

Phone: 714-893-8529 FAX: 714-894-9492

E mail: sales@blue-white.com or techsupport@blue-white.com URL: www.blue-white.com

TABLE OF CONTENTS

<u>Section</u>	<u>Heading</u>	<u>Page</u>
1.0	Introduction	3
1.1	Unpacking	3
1.2	Available Models	3
2.0	Specifications	4
2.1	Agency Listings	4
3.0	Features	5
4.0	Installation	6
4.1	Mounting Location	6
5.0	Input Power Connection	7
6.0	How to install the Tubing and Fittings	8
7.0	How to Operate A3V	9
8.0	Menu Navigation	12
9.0	Configuration Menu	13
9.1	Language Selection	13
9.2	Display Rate (units of measure)	14
9.3	Reset Factory Defaults	14
10.0	Input Setup	15
	Pump Calibration	15
10.1	Manual Adjust (manual speed adjust)	16
10.2	4 - 20 mA Input	17
10.3	0 - 10 VDC Input	18
10.4	Frequency Input (Hz)	19
10.5	Pulse Batch (low speed batch)	20
10.6	Manual Cycle Adjust (repeating cycle timer)	21
10.7	Dispensing	22
10.8	Manual Dosing	23
10.9	Proportional Dosing	24
11.0	Contact Closure Input	25
12.0	Set FVS (flow verification system)	26
13.0	Output Setup (software)	27
	Signal, Relay, & Contact Closure	
13.1	Signal Output (software)	28
14.0	External Signal Connections	29
15.0	Tube Replacement	31
16.0	TFD (tube failure detection)	34
17.0	Pump Tube Timer	34
18.0	Reverse Rotor Rotation	35
19.0	How To Maintain the Pump	36
20.0	Pump Head - Exploded View and Part No.	37

1.0 Introduction

Congratulations on purchasing the A3 variable speed Peristaltic Metering Pump. A peristaltic pump is a type of positive displacement pump used for pumping a variety of fluids.

Your A3 pump is pre-configured for the tubing that shipped with your metering pump. The tubing assembly has an Identification number printed for easy re-order.

Please Note: Your new A3 pump has been pressure tested at the factory with clean water before shipping. You may notice trace amounts of clean water in the pre-installed tube assembly. This is part of our stringent quality assurance program at Blue-White Industries.

1.1 Unpacking

Check that all components are present. Inspect components for damage in transit. If anything is missing or damaged, contact your distributor immediately.

Your package should contain:

- 1 - Metering pump
- 2 - Pump tube assemblies (one is pre-installed at the factory)
- 1 - Tube Installation Tool
- 1 - Suction tube strainer Polypropylene
- 1 - Ceramic tubing weight
- 1 - 10' (3.05 meters) Length of clear PVC suction tubing
- 1 - 10' (3.05 meters) Length of opaque Polyethylene (LLDPE) high pressure discharge tubing
- 1 - Injection fitting with internal back-flow check valve
- 2 - Mounting hardware kit (Stainless Steel)

1.2 Available Models

Max GPH	Max LPH	Max PSI	Pump Tube Material	A3F Series model numbers		A3V Series model numbers	
				115V AC	230V AC	115V AC	230V AC
1	3.9	125	Norprene	A3F14-SND	A3F15-SND	A3V14-SND	A3V15-SND
4	15	125	Norprene	A3F14-SNF	A3F15-SNF	A3V14-SNF	A3V15-SNF
9	34.2	125	Norprene	A3F14-SNH	A3F15-SNH	A3V14-SNH	A3V15-SNH
12.7	48	125	Norprene	A3F14-SNJ	A3F15-SNJ	A3V14-SNJ	A3V15-SNJ
16.6	63	125	Norprene	A3F14-SNK	A3F15-SNK	A3V14-SNK	A3V15-SNK
2.4	9	65	Tygothane	A3F14-SGE	A3F15-SGE	A3V14-SGE	A3V15-SGE
5	18.9	65	Tygothane	A3F14-SGG	A3F15-SGG	A3V14-SGG	A3V15-SGG
12	45.6	65	Tygothane	A3F14-SGH	A3F15-SGH	A3V14-SGH	A3V15-SGH
2.1	7.8	125	Norprene	A3F24-SND	A3F25-SND	A3V24-SND	A3V25-SND
7.9	30	125	Norprene	A3F24-SNF	A3F25-SNF	A3V24-SNF	A3V25-SNF
17.4	66	125	Norprene	A3F24-SNH	A3F25-SNH	A3V24-SNH	A3V25-SNH
25.3	96	125	Norprene	A3F24-SNJ	A3F25-SNJ	A3V24-SNJ	A3V25-SNJ
33.3	126	125	Norprene	A3F24-SNK	A3F25-SNK	A3V24-SNK	A3V25-SNK
4.6	17.4	65	Tygothane	A3F24-SGE	A3F25-SGE	A3V24-SGE	A3V25-SGE
10.1	38.4	65	Tygothane	A3F24-SGG	A3F25-SGG	A3V24-SGG	A3V25-SGG
24.9	94.2	65	Tygothane	A3F24-SGH	A3F25-SGH	A3V24-SGH	A3V25-SGH

Subject to change without notice.

2.0 Specifications

Maximum Working Pressure	125 psig (8.6 bar) Norprene tubing 65 psig (4.4 bar) Tygothane tubing
Maximum Fluid Temperature	130° F / 54° C
Operating Temperature	14°F to 115°F (-10°C to 46°C)
Storage Temperature ..	-40°F to 158°F (-40°C to 70°C)
Duty Cycle	Continuous
Operating Voltage (model Specific)	Voltage is automatically detected and adjusted by power supply. Input power range is 96VAC to 264VAC 50/60 Hz.
Amp Draw:	2.5 amp @ 125V AC / 60Hz 1.4 amp @ 250V AC / 60Hz 1.4 amp @ 250V AC / 50Hz
Power Cord Plug Type (Model Specific)	115V60Hz = NEMA 5/15 (USA) 230V60Hz = NEMA 6/15 (USA) 220V, 240V50Hz = CEE 7/VII (EU)
Accuracy	+/- 0.5% full scale (after calibration, pre calibrated @ factory with water)
Maximum Viscosity	5,000 Centipoise
Maximum Suction Lift	30 ft. water, 0psig (4.5 m, 0 bar)
Output Adjustment Range	1-100% in 0.1% increments (resolution)
Display	VGA backlit LCD, UV resistant
Display Languages	English, Spanish, French or German
Keypad	Ten - Button positive action tactile switch keypad
Security	Programmable 4 - digit password
Enclosure	NEMA 4x (Ip66), Powder coated aluminum
Dimensions	8.00H x 10.50 W x 14.63 D inches (203H x 267W x 371D mm)
Approximate shipping wt	32 lb. (14.5 Kg)
Approximate pump wt.	27.5 lb.
Wetted Materials	Tubing: Norprene or Tygothane (depending on model) Tube fittings: PVDF (Kynar®)
Wetted Material - Ancillary Items	Discharge tubing: Polyethylene tubing (3/8" O.D.) Suction tubing: PVC tubing (3/8: O.D.) Injection fitting: PVDF (Kynar®), Elastomers (o-rings) Viton / Aflas, Ceramic ball, Hastelloy spring Foot strainer (for suction end): Polypropylene Tube Weight (for suction end): Ceramic

2.1 Agency Listings



This pump is ETL listed to conforms to the following:
UL Standard 778 as a motor operated water pump
CSA Standard C22.2 as process control equipment



This pump complies to the Machinery Directive 98/37/EC, BS EN 60204-1, Low Voltage Directive 73/23/EC BS EN 61010-1, EMC Directive 89/336/EC, BS EN 50081-1/BS EN 50082-1.

Symbol	Explanation
	WARNING, risk of electric shock
	CAUTION, refer to users' guide
	GROUND, PROTECTIVE CONDUCTOR TERMINAL

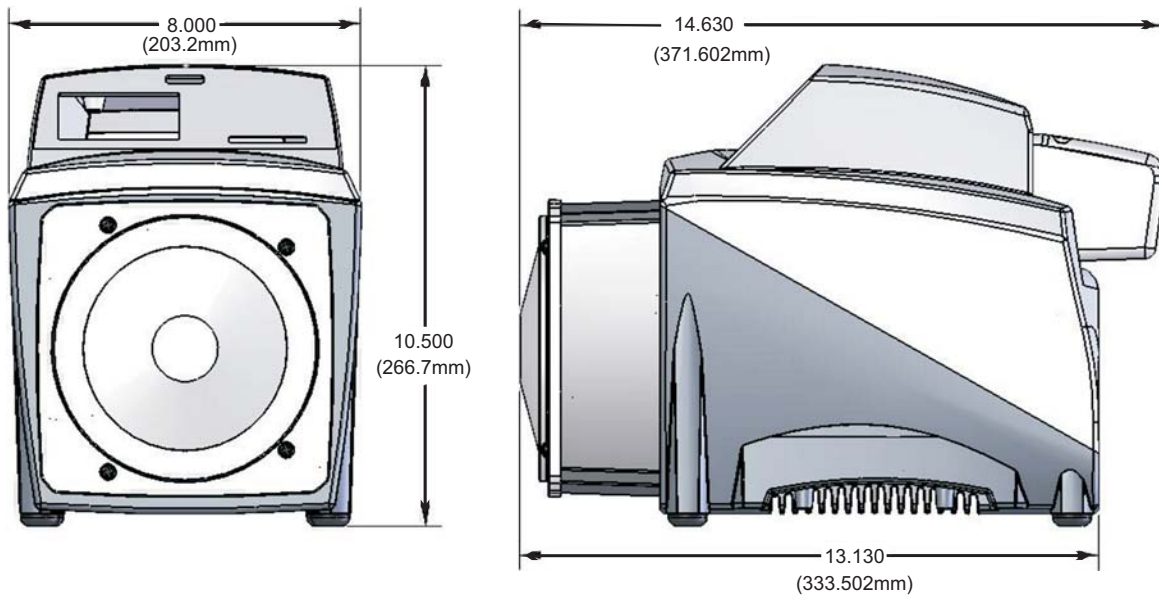

3.0 Features

- Peristaltic pump design does not have valves that can clog requiring maintenance.
- Self priming - even against maximum line pressure. By-pass valves are not required. Cannot vapor lock or lose prime.
- Output volume is not effected by changes in back pressure.
- Two pump tubes supplied with each pump. No extra tubing required. One tube is pre-installed for you convenience.
- Remote Start / Stop: 6 - 30 VDC contact closure or 0 VDC dry contact closure
- Inputs include: 4-20mA, 0-10Vdc, and Pulse inputs for external speed control
- Operator friendly digital touch pad with menu driven software.
- VGA Graphic backlit LCD - displays motor speed, feed rate, input signal values, service and alarm status.
- Outputs include: Scalable 4-20mA and pulse (frequency), One 10 amp relay and three contact closures assignable to monitor TFD, FVS, motor on, and operating mode error.
- Automated Parts Per Million dosing (requires analog or a pulse input from a flow meter and/or controller)
- Manual Parts Per Million dosing (does not require a flow meter or controller for input)
- One button prime mode for easy priming.
- Output rates to: 33.3 GPH (126 LPH).
- Output pressures to 125 PSI.
- Zero maintenance brushless variable speed motor.
- Specially engineered tubing for long life at high pressures.
- Motor reverse feature to increase tube life.
- Pump head safety feature: When pump head cover is removed, pump automatically stops, and enters maintenance mode.
- Rotor design enables pump to handle same maximum pressure in either direction (clockwise and counter clockwise).
- Single piece rotor design means no flexing and increases accuracy (no springs or hinges in pump head).
- Annealed, clear acrylic pump head cover for added strength and chemical resistance.
- Patented Tube Failure Detection (TFD) system. Senses tube failure by detecting chemical in pump head.
- Compatible with Blue-White's output Flow Verification Sensor (FVS) system.
- 10 ft. PVC suction tube, 10 ft. PE discharge tubing, injection fitting, foot strainer, and mounting brackets supplied with each pump.

Enclosure Rating:

NEMA 4X: Constructed for either indoor or outdoor use to provide a degree of protection to personnel against incidental contact with enclosed equipment; to provide a degree of protection against falling dirt, rain, sleet, snow, windblown dust, splashing water, and hose-directed water; and that will be undamaged by external formation of ice on enclosure.

Ip66: No ingress of dust; complete protection against contact. Water projected in powerful jets against enclosure from any direction shall have no harmful effects.

4.0 Installation

CAUTION ⚠	Risk of chemical overdose. Be certain pump does not overdose chemical during backwash and periods of no flow in circulation system.
CAUTION ⚠	Always wear protective clothing, face shield, safety glasses and gloves when working on or near your metering pump. Additional precautions should be taken depending on solution being pumped. Refer to MSDS precautions from your solution supplier.
CAUTION ⚠	All diagrams are strictly for guideline purposes only. Always consult an expert before installing metering pump on specialized systems. Metering pump should be serviced by qualified persons only.

4.1 Mounting Location

Choose an area located near chemical supply tank, chemical injection point, and electrical supply. Install pump where it can be easily serviced.

- Mount pump to a secure surface using enclosed mounting hardware.
- Mount pump close to injection point. Keep inlet (suction) and outlet (discharge) tubing as short as possible. Longer discharge tubing increases back pressure at pump head.
- Your solution tank should be sturdy. Keep tank covered to reduce fumes. Do not mount pump directly over your tank. Chemical fumes may damage unit. Mount pump off to side or at a lower level than chemical container.

TYPICAL INSTALLATION

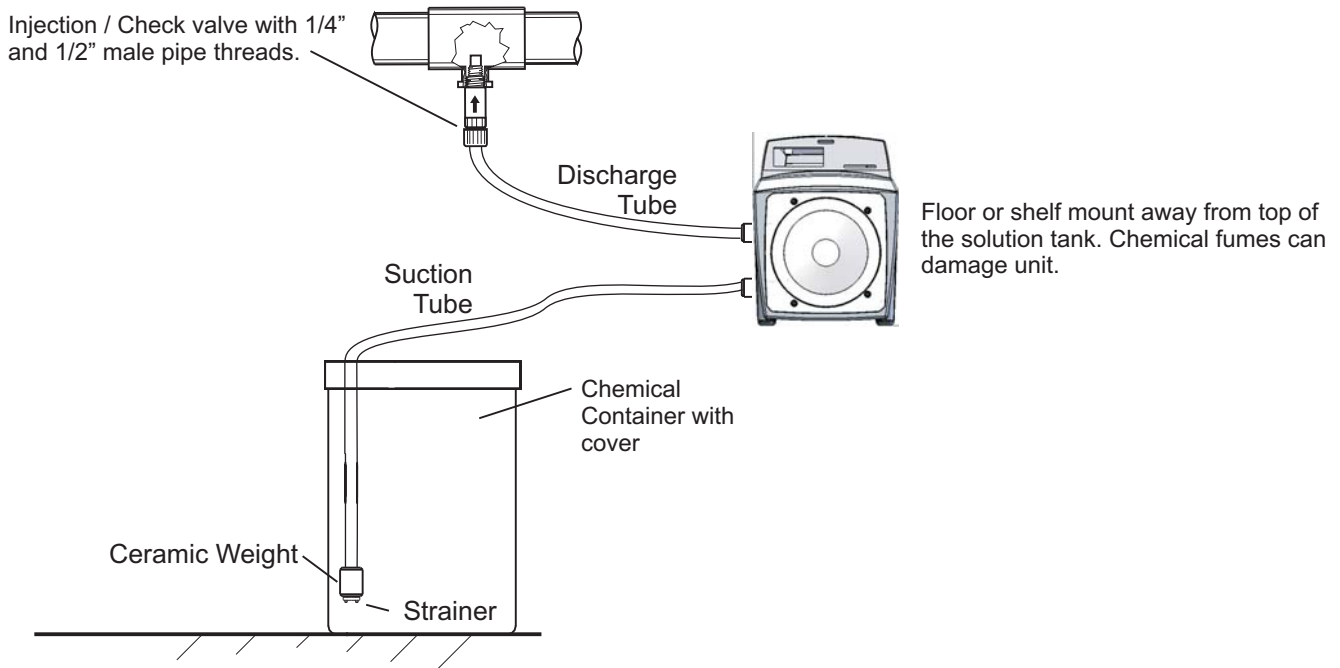

Extended Brackets Model Number 72000-380



Stainless Steel extended brackets allow pump to be securely mounted to most any surface; floor, shelf, or skid. Brackets lift pump up 4-1/2 inches (11.43 cm), for easy pump access in hard to reach areas.

- Raise metering pump 4-1/2 inches (11.43 cm) off ground or a surface.
- Made out of tough Stainless Steel.
- Provides a stable mounting surface.

Model #	Description
72000-380	Extended Mounting Bracket, 1 Pair, SS, 4 SS Screws



5.0 Input Power Connections

WARNING 	Risk of electric shock – this pump is supplied with a grounding conductor and grounding-type attachment plug. To reduce risk of electric shock, be certain that it is connected only to a properly grounded, grounding-type receptacle.
WARNING 	Electrical connections and grounding (earthing) must conform to local wiring codes.

- Be certain to connect pump to proper supply voltage. Using incorrect voltage will damage pump and may result in injury. Voltage requirement is printed on pump serial label.
- Input power range is 96VAC to 264VAC 50/60 Hz.
- Voltage Selection is automatically detected and adjusted by power supply. No mechanical switch necessary.
- Use voltage your power cord is rated for.
- Pump is supplied with a ground wire conductor and a grounding type attachment plug (power cord). To reduce risk of electric shock, be certain that power cord is connected only to a properly grounded, grounding type receptacle.
- Never strap control (input / output) cables and power cables together.
- **Power Interruption:** This pump has an auto-restart feature which will restore pump to operating state it was in when power was lost.

Note: When in doubt regarding your electrical installation, contact a licensed electrician.

Three power cord plug types available. Power cord length is 6 feet (3.83 meters)

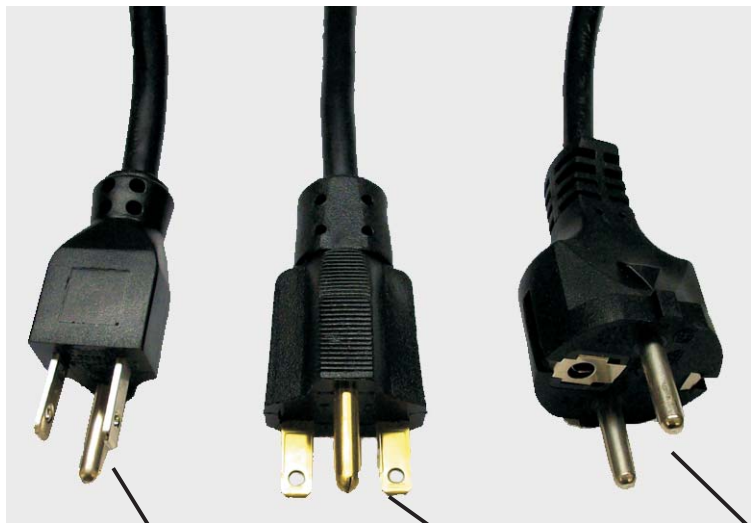

115V 60Hz
NEMA 5/15 (USA)
max: 125V AC

230V 60Hz
NEMA 6/15 (USA)
max: 250V AC

240V 50Hz
CEE 7/VII (EU)
max: 250V AC

Symbol	Explanation
	GROUND, PROTECTIVE CONDUCTOR TERMINAL

6.0 How To Install Pump Accessories

CAUTION Proper eye and skin protection must be worn when installing and servicing pump.

CAUTION This Pump Has Been Evaluated for Use with Water Only.

Pump accessories include: Suction tubing, discharge tubing, foot strainer, ceramic weight, injection fitting / quill
 Accessories are provided for your convenience.

- **Inlet Tubing (suction)** - Locate inlet fitting of Pump Tube. Remove tube nut. Slide tube nut onto tubing with threads facing pump head tube fitting. Push clear PVC suction tubing onto compression barb of fitting. Use tube nut to secure tube. Hand tighten only.
- **Strainer (suction end)** - Trim inlet end of suction tubing so foot strainer will rest approximately two inches from bottom of solution tank. This will prevent sediment from clogging strainer. Slip ceramic weight over end of suction tube. Press strainer into end of tube. Secure ceramic weight to strainer. Drop foot strainer into solution tank.
- **Outlet Tubing (discharge)** - Locate outlet fitting of Pump Tube. Remove tube nut. Push tube nut onto tubing with female threads facing pump head tube fitting. Push opaque outlet (discharge) tubing onto compression barb of the fitting. Use tube nut to secure tube. Hand tighten only.

Keep outlet tube as short as possible.

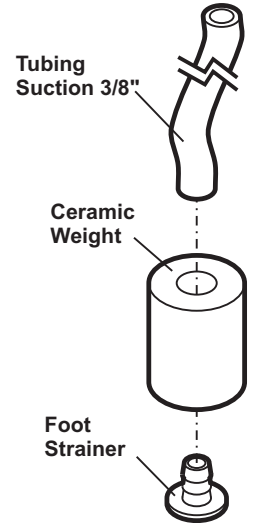

- **Injection/Check Valve Fitting Installation (injection point)**- Injection/Check valve fitting is designed to install directly into either 1/4" or 1/2" female pipe threads. This fitting will require periodic cleaning, especially when injecting fluids that calcify such as sodium hypochlorite. Install Injection/Check valve directly into piping system. Use Teflon thread sealing tape on pipe threads. Push opaque outlet (discharge) tubing onto compression barb of Injection/Check valve fitting. Use tube nut to secure tube. Hand tighten only.

Injection Fitting - Exploded View

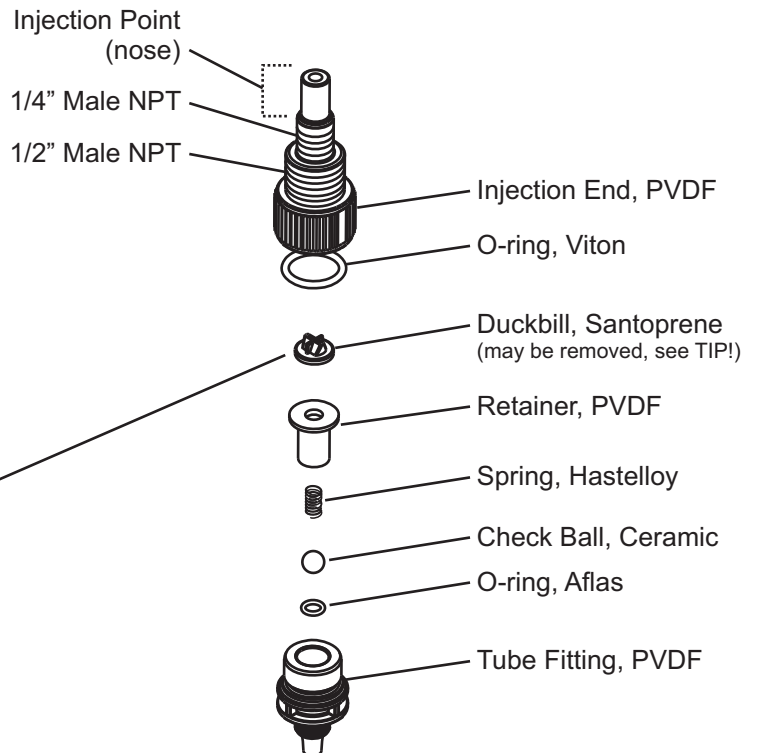

Tip!



Duckbill is used to help reduce calcium buildup when injecting chemicals that calcify (such as sodium hypochlorite). **Duckbill** may add additional back pressure to pump (up to 7 psi). **Duckbill** may be removed if desired. You may also want to remove **duckbill** when metering viscous fluids.

7.0 How To Operate A3V

A3V Series, Control Panel - Button Operation

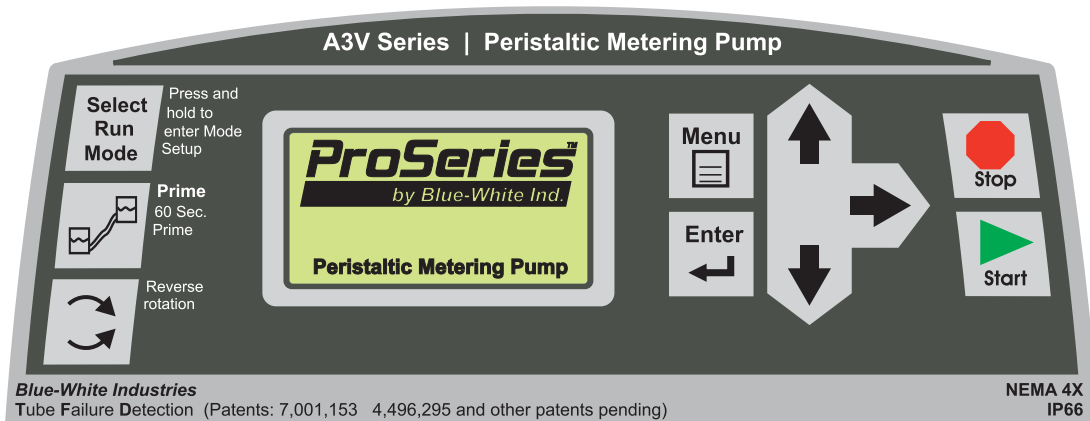

To STOP pump at any time

Pump can be stopped at any time by pressing STOP button. STOP button overrides all other controls and stops pump. Display will read OFF if pump has been stopped in this manner. Pump will not respond to incoming input signals while in OFF state. When START button is pressed, pump will start according to it's previous operating state.



To START pump

After programming / configuring pump, you must press START button to start pump. If pump is setup for Manual Mode, pump will immediately start pumping at your preselected metering rate. If pump is configured to accept an incoming signal, pump will begin "listening" for incoming signal.



UP Arrow

UP arrow is used only when configuring your pump. When configuring your pump, UP arrow will move selected digit up. For example, to move selected digit from "0" to "4", press UP arrow four times. Numbers will loop back to "0" if you should pass your desired number. UP arrow is also used to navigate through menu structure of pump.



DOWN Arrow

DOWN arrow is used only when configuring your pump. When configuring your pump, DOWN arrow will move selected digit down. For example, to move selected digit from "4" to "0", press DOWN arrow four times. Numbers will loop back to "9" if you should pass your desired number. DOWN arrow is also used to navigate through menu structure of pump.



RIGHT Arrow

RIGHT arrow work as a runtime function and is also used when configuring your pump.

Runtime Function:

While pump is operating (in any Run Mode), you can view useful information regarding your current Run Mode by pressing RIGHT arrow.

If pump is using input signals to operate (such as 4-20 mA), you can view current input signal by pressing RIGHT arrow.

Programing / configuring your pump:

Right arrow is used to select next digit to right.

Menu

**To enter MENU**

When MENU button is pressed, pump will stop. Pump will not respond to incoming input signals while in MENU system of pump.

+ Configuration

- **Language** - Factory default is English
- **Set Password** - Factory default is no password
- **Display Rate** - units of measure (% Speed, RPM, ML/min, Oz/min, Liter/Hr, Gal/Hr, Gal/Day)
- **Reset Factory Defaults**

+ Input Setup

- **Select RPM** - Pre-configured at factory (DO NOT CHANGE, unless you order a different RPM gear motor from Blue-White)
- **Max Flowrate** - Pre-configured at factory. Also used for field calibration.
- **Input Modes (also referred to as Run Mode)**
 - Manual Speed Adjust - Input desired metering rate
 - 4-20 mA Input
 - 0-10 Volts DC
 - Frequency Input - High speed pulse signal
 - Pulse Batch Input - 1 to 9999 pulses
 - Manual Cycle Adjustment - Fixed speed (1% to 100%), total cycle time (up to 999.9 seconds) for a set pump Run-Time per cycle (up to 999.9 seconds)
 - Dispensing - Input milliliters to dispense at desired motor speed
 - Manual Dosing - Manual PPM dosing to a known fluid volume
 - Proportional Dosing - PPM dosing using a pulse signal input (from a flow meter)
- **Contact Input (0 - 30 Volt DC)**
- **Set FVS** (flow verification system)

+ Output Setup

- **Signal Output**
 - 4-20 mA Output - Sends configurable output signal to another pump or other external device
 - Frequency Output (pulse) - Sends configurable output signal to another pump or other external device
 - Disable (factory default)
- **Relay Output (10 amp)**
 - Both, TFD / FVS (factory default)
 - TFD - Tube Failure Detection
 - FVS - Flow Verification System
 - Monitor Signal Input
 - Monitor Signal Output
 - Monitor Pump Run / Fail
 - Disable
- **Contact Closure #1 (0 - 30 Volt DC)**
 - Monitor Signal Input
 - Monitor Signal Output
 - Monitor Pump Run / Fail
 - Both, TFD / FVS
 - TFD - Tube Failure Detection
 - Disable
- **Contact Closure #2 (0 - 30 Volt DC)**
Same selections as Contact Closure #1
- **Contact Closure #3 (0 - 30 Volt DC)**
Same selections as Contact Closure #1

Enter

**ENTER**

ENTER button is used only when configuring your pump. When configuring your pump, use ENTER button to make / confirm a selection.

Select Run Mode

SELECT RUN MODE

SELECT RUN MODE button will allow you to scroll and select current Run Mode (operating Input Mode). Current Run Mode (Operating Input Mode) is displayed along top left portion of LCD.

Example: If pump is currently running in **Manual Speed Adjust** mode and you press SELECT RUN MODE button, pump will disable **Manual Speed Adjust** mode setting and activate next Run Mode (which is **4-20 mA Input** mode). You can scroll back to your desired Run Mode by continuously pressing SELECT RUN MODE button until you reach your desired Run Mode.

Note: You can configure multiple Run Modes (Operating Input Modes). Pump can only run in ONE Run Mode (Operating Input Mode) at a time.

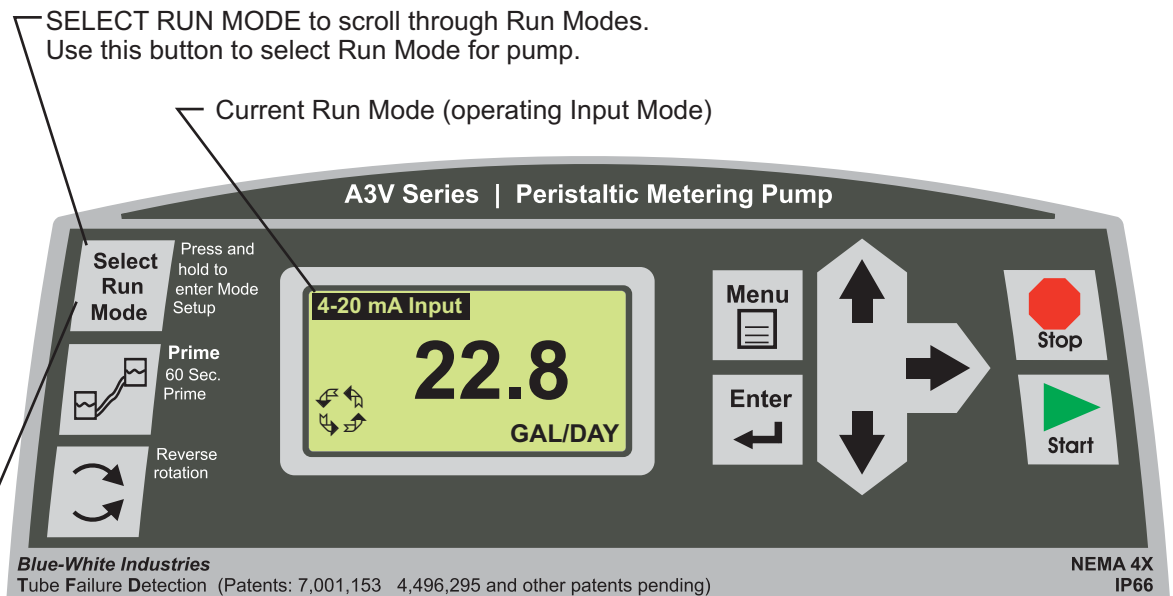

SELECT RUN MODE button also serves as a shortcut button. **Press and Hold** SELECT RUN MODE button to enter program menu for currently displayed Run Mode. Once you have programed your Run Mode, Press ENTER to save changes. **Press and Hold** SELECT RUN MODE button to jump back to current Run Mode of pump. **Press START** button to start pump with new settings.

Run Mode (operating Input Mode)



To PRIME pump

Press PRIME button to start 60 second prime feature. Pump will run at full speed for 60 seconds or until STOP or START button is pressed. STOP button will stop pump and display will read OFF. START button will stop prime feature and jump back into previous operating state.



To REVERSE ROTATION of rotor

Press REVERSE ROTATION button to reverse flow. A3V pump display will guide you through reverse rotor rotation process.

Caution!

Discharge line is under pressure! Safely relieve discharge line pressure by using a pressure relief valve. REMOVE DISCHARGE LINE PRESSURE BEFORE DISCONNECTING TUBING.

8.0 Menu Navigation

– Sample screen shots –

Use MENU button to enter menu for setting up pump.

Use UP or DOWN arrows to navigate through menu.

Active option appears on pump display in **inverse** text.

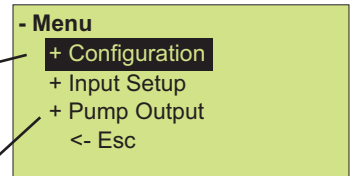

Plus symbol + signifies top of a menu tree. This means you can go further within menu.

Within Menu of pump, each screen you enter will have a title located along top. This will display the menu that is currently active, or this will be the setting you are configuring.

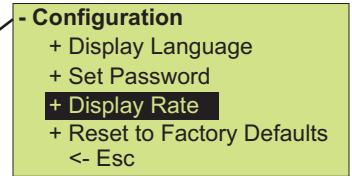

To back out of menu, select <- Esc line located at end of list. Then press ENTER button. This will take you back one level.

When menu list extends above or below height of display, a scroll bar will appear on left side. Press DOWN arrow to scroll down to end of list to see a list of all available options.

Scroll bar example:

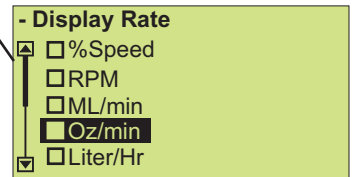

While making a selection where only one choice is allowed, you will see a radio button.

Radio button example: Solid black means item is selected
 Outline with no fill means item is not selected

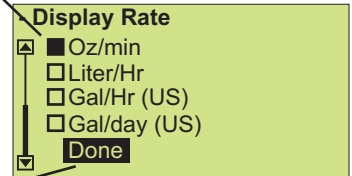

In a screen where you are making changes, you will see the word **Done** located at bottom of list. You must select **Done** in order to leave screen (whether you made a change or not). Selecting **Done** will take you back to parent level.

When inputting a numerical value, use UP or DOWN arrow to scroll through 0 - 9. To move over to next digit use RIGHT arrow. If you pass your desired digit, you can continuously press RIGHT arrow until you scroll reach to your desired digit.

Numeric value example: **0000**

9.0 Configuration Menu

Below is menu structure for Configuration screens.

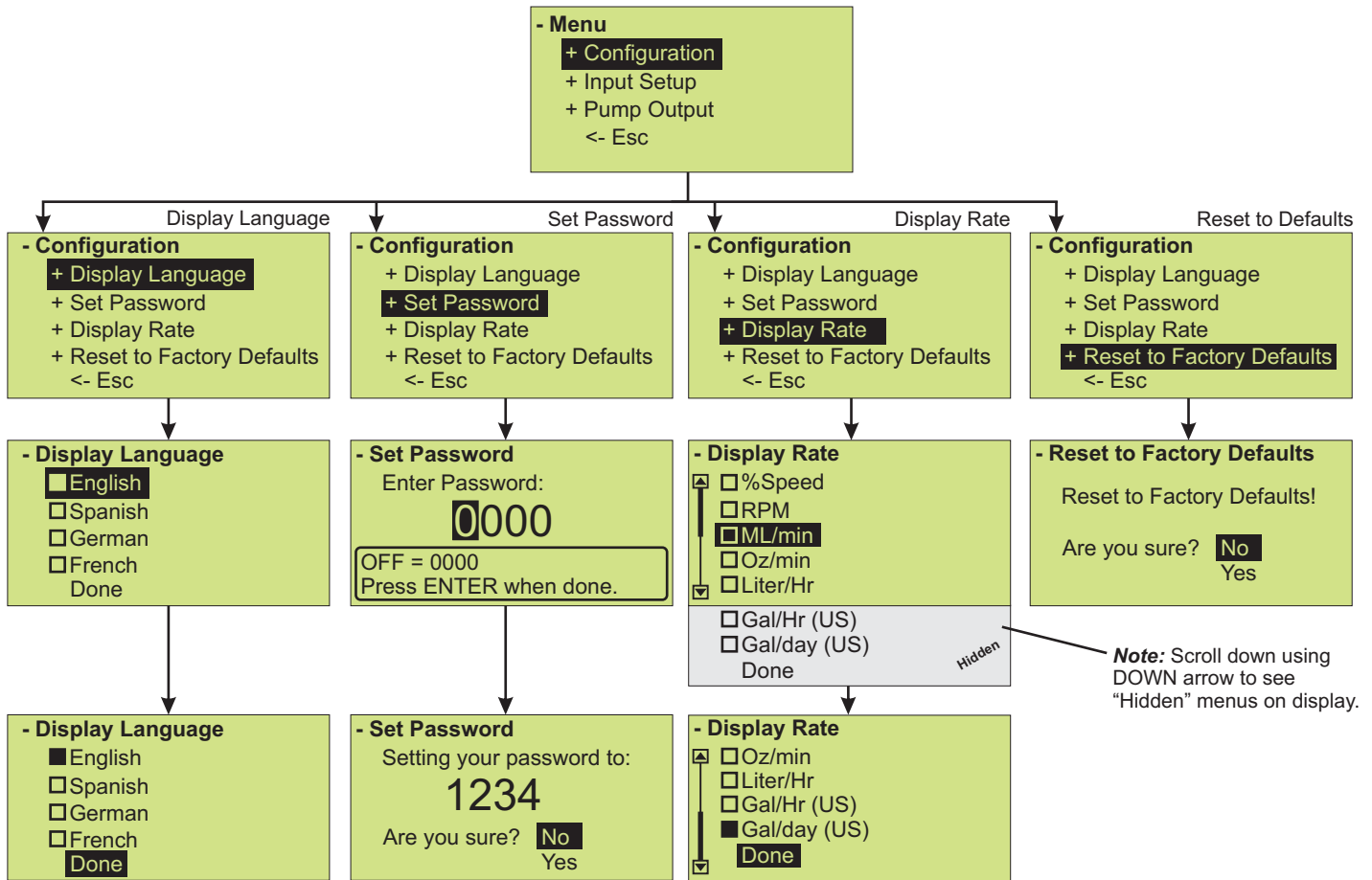

9.1 Language Selection

Press MENU button to enter menu structure for setting up pump.

Select **Configuration** and Press ENTER button.

Select **Display Language** and Press ENTER button.

Select your desired language, then Press ENTER.

Note: English is default language.

Select **Done** at bottom of list to confirm your selection. Press ENTER button.

Select **<-Esc** on following screens to move back up to desired menu location.

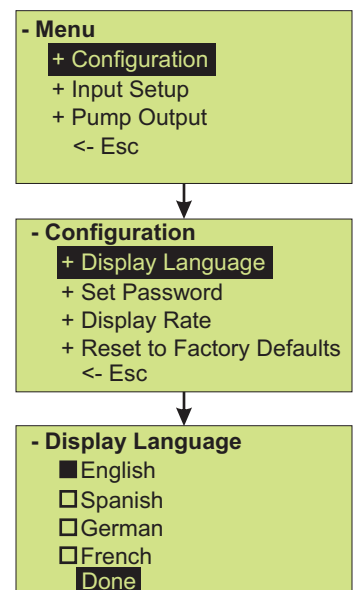

9.2 Display Rate (Units of Measure)

By default, pump will display %Speed (motor speed) and RPM. It is recommended you select an additional **Display Rate**. After selecting another **Display Rate** (such as ML/Min), pump will still display %Speed and RPM along with your selected Display Rate.

Press MENU button to enter menu structure for setting up pump.

Select **Configuration** and Press ENTER button.

Select **Display Rate** and Press ENTER button.

Select your desired Display Rate (unit of measure). Note: %Speed and RPM will always be active and available to view when pump is in operation.

Select **Done** at bottom of list to confirm your selection and to return back to previous screen. Press ENTER button.

Select **<-Esc** on following screens to move back up to desired menu location.

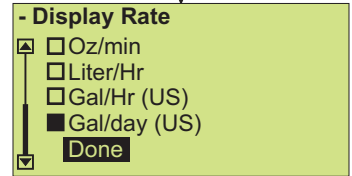
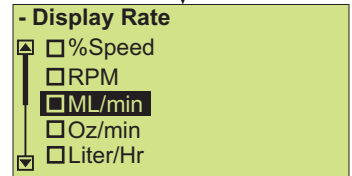
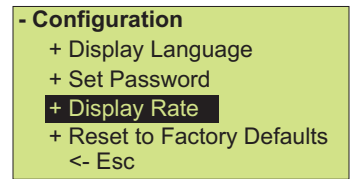

Tip! 

While pump is operating in any Run Mode, you can view %Speed, RPM, plus another Display Rate (depending on your selection above). Press RIGHT arrow while pump is in any Run Mode. RIGHT arrow is a convenient way to scroll through multiple read-only screens during normal operating mode of pump.

Note: This is a read-only feature, no changes can be made while in Run Mode.

9.3 Reset Factory Defaults

This will reset pump to factory defaults. This will restore pump to original configuration when it left the factory.

Press MENU button to enter menu structure for setting up pump.

Select **Configuration** and Press ENTER button.

Select **Reset to Factory Defaults** and Press ENTER button.

Select **No** or **Yes**, then ENTER button.

Select **<-Esc** on the following screens to move back up to desired menu location.

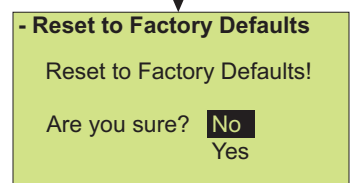
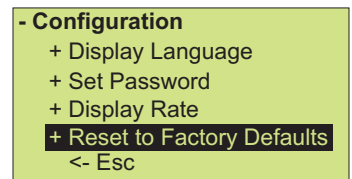

10.0 Input Setup

Below is menu structure for INPUT SETUP selection.

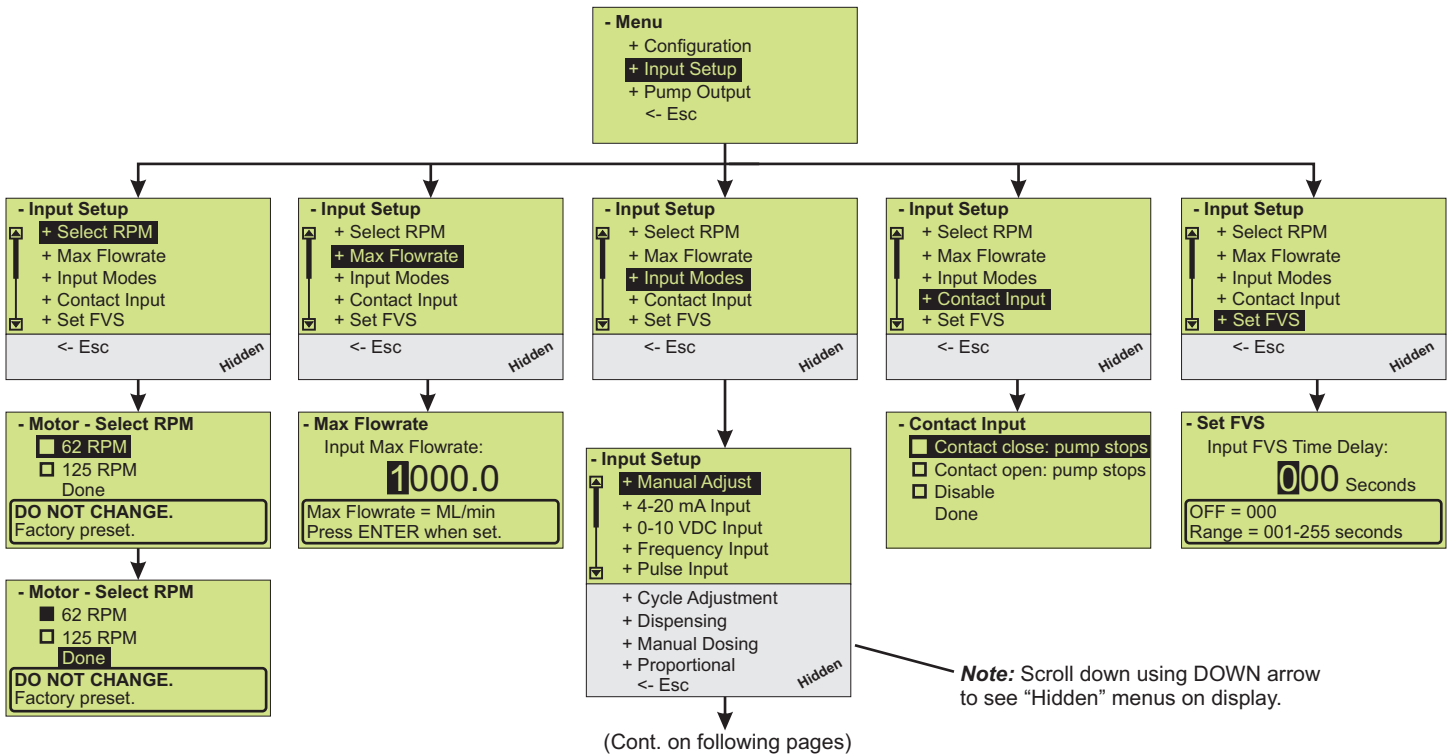

Select RPM (do not change)

To Select a different RPM motor. This menu should be avoided by operator. Change this setting ONLY when motor has been replaced with a different RPM motor. If the wrong RPM is selected the pump WILL NOT operate correctly.

Max Flowrate

To calibrate your pump. This setting is pre-configured at factory based on model number that was originally ordered and is based on tube size and motor RPM. Pump has been calibrated with water. You can re-calibrate pump using this menu.

Pump Calibration: Output pressure will not affect pump flowrate (feed rate). If solution you're metering is more viscous than water, you may want to re-calibrate your pump using your solution.

With pump installed under normal operating conditions, place suction tubing in a graduated container.

Fill container with same solution normally injected, and run pump until all air is removed. Prime pump.

Refill container if necessary, and with suction in solution, note amount of solution in container.

Using a stopwatch or timer, run pump for a measured amount of time (example: 1 minute). Note amount of solution pumped during that time.

Input your results in "Max Flowrate" screen using ML/Min (see above). Your pump will now be calibrated for your solution.

Tip: The longer the testing time, the more accurate the measurement.

Input Modes

To configure your pumps Run Modes. Use this menu to setup your desired operating mode. This manual will cover each step in detail later.

Contact Input (remote control)

Contact Closure Input feature is used to Start and Stop pump remotely. Default setting is DISABLE.

Set FVS (Flow Verification System)

Set Flow Verification time delay. Use this feature if you are using a Blue-White flow verification sensor to monitor flow output. Default setting is OFF.

Tip!

Select Run Mode Press and hold to enter Mode Setup

SELECT RUN MODE button also serves as a shortcut button. **Press and Hold** SELECT RUN MODE button to enter program menu for currently displayed Run Mode. Once you have programed your Run Mode, Press ENTER to save changes. **Press and Hold** SELECT RUN MODE button to jump back to current Run Mode of the pump. Then **Press** START button to start pump with new settings applied.

Run Mode (operating Input Mode)



10.1 Manual Adjust (manual speed adjust)

Used to manually control speed of pump. Set % (percent) Motor Speed in this menu.

Navigate to **Manual Speed Adjust** menu by using short-cut method described above, or by pressing MENU button, then selecting Input Setup, Input Modes, and then **Manual Adjust**.

Press UP or DOWN arrow to scroll through 0 - 9 on selected digit.

Press RIGHT arrow to scroll over to next digit to right. If you pass your desired digit, you can easily scroll back by continuously pressing RIGHT button.

Press ENTER to save changes.

If you used short-cut to enter Manual Speed Adjust setup, then just press and hold Select Run Mode button until Run Mode screen is displayed.

If you used Menu button to navigate to Manual Speed Adjust setup, you must navigate back out of menu structure. To do this you must select <-Esc at bottom of every screen menu until you see Run Mode screen displayed.

Tip! This feature can be combined with **Contact Input** feature to allow for remote Start and Stop of pump. Can be used with PLC, foot pedal, push button, or other external controls.

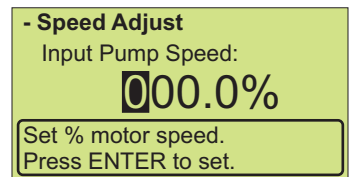

Tip!



In Manual Speed Adjust mode, you can view pump output by pressing RIGHT arrow (see screen shot). RIGHT arrow is a convenient way to scroll through multiple read-only screens during normal operating mode of pump.

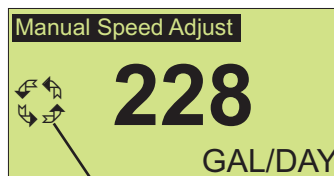

Displays current rotor direction

10.2 4 - 20 mA Input

Used to remotely control pump with an incoming 4-20 mA signal.

Default settings: 4 mA = 0% motor speed
20 mA = 100% motor speed

Navigate to **4 - 20 mA Input** menu by using short-cut method described at beginning of section, or by pressing MENU button, then selecting Input Setup, Input Modes, and then **2 - 20 mA Input**.

Press UP or DOWN arrow to scroll through 0 - 9 on selected digit.

Press RIGHT arrow to scroll over to next digit to right. If you pass your desired digit, you can easily scroll back by continuously pressing RIGHT button.

Press ENTER to save changes.

Continue this process until all four screens have been configured.

If you used short-cut to enter 4-20 mA input setup, then just press and hold Select Run Mode button until Run Mode screen is displayed.

If you used Menu button to navigate to 4-20 mA input setup, you must navigate back out of menu structure. To do this you must select <-Esc at bottom of every screen menu until you see Run Mode screen displayed.

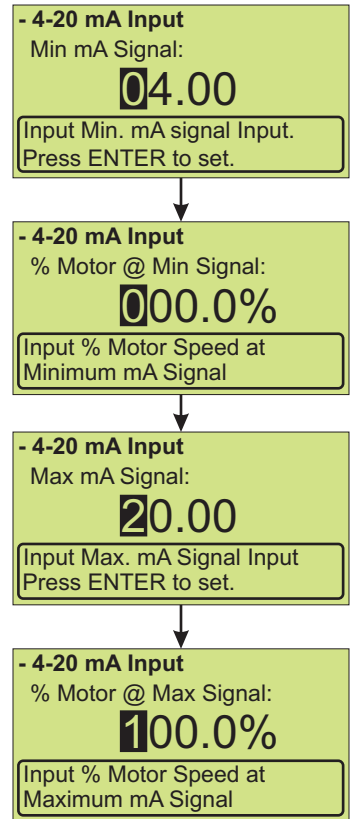

Example 1

4 mA = 0% Pump Output
20 mA = 100% Pump Output

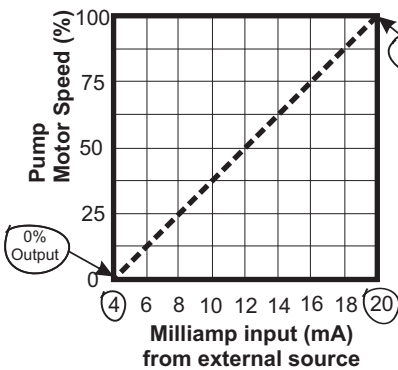

Example 2

4 mA = 100% Pump Output
20 mA = 0% Pump Output

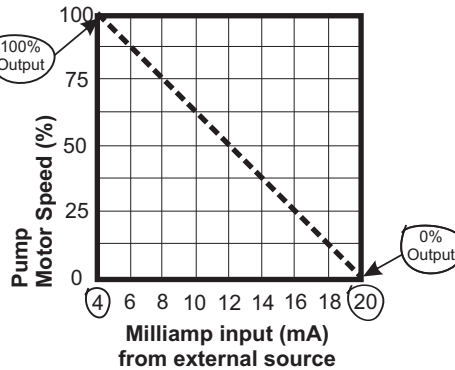

Example 3

4 mA = 20% Pump Output
16 mA = 43.8% Pump Output

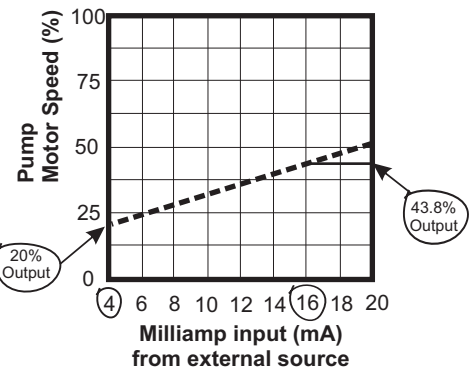

Tip! 

In 4 - 20 mA mode, you can view current incoming signal by pressing RIGHT arrow (see screen shot). RIGHT arrow is a convenient way to scroll through multiple read-only screens during normal operating mode of pump.

- Screen Shot -

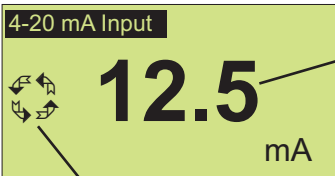

Displays current incoming signal

Displays current rotor direction

10.3 0 - 10 VDC Input (Volt DC)

Used to remotely control pump with an incoming 0-10 VDC signal.

Default settings: 0 VDC = 0% motor speed
10 VDC = 100% motor speed

Navigate to **0 - 10 VDC Input** menu by using short-cut method described at beginning of section, or by pressing MENU button, then selecting Input Setup, Input Modes, and then **0 - 10 VDC Input**.

Press UP or DOWN arrow to scroll through 0 - 9 on selected digit.

Press RIGHT arrow to scroll over to next digit to right. If you pass your desired digit, you can easily scroll back by continuously pressing RIGHT button.

Press ENTER to save changes.

Continue this process until all four screens have been configured.

If you used short-cut to enter 0 - 10 VDC Input setup, then just press and hold Select Run Mode button until Run Mode screen is displayed.

If you used Menu button to navigate to 0 - 10 VDC Input setup, you must navigate back out of menu structure. To do this you must select <-Esc at bottom of every screen menu until you see Run Mode screen displayed.

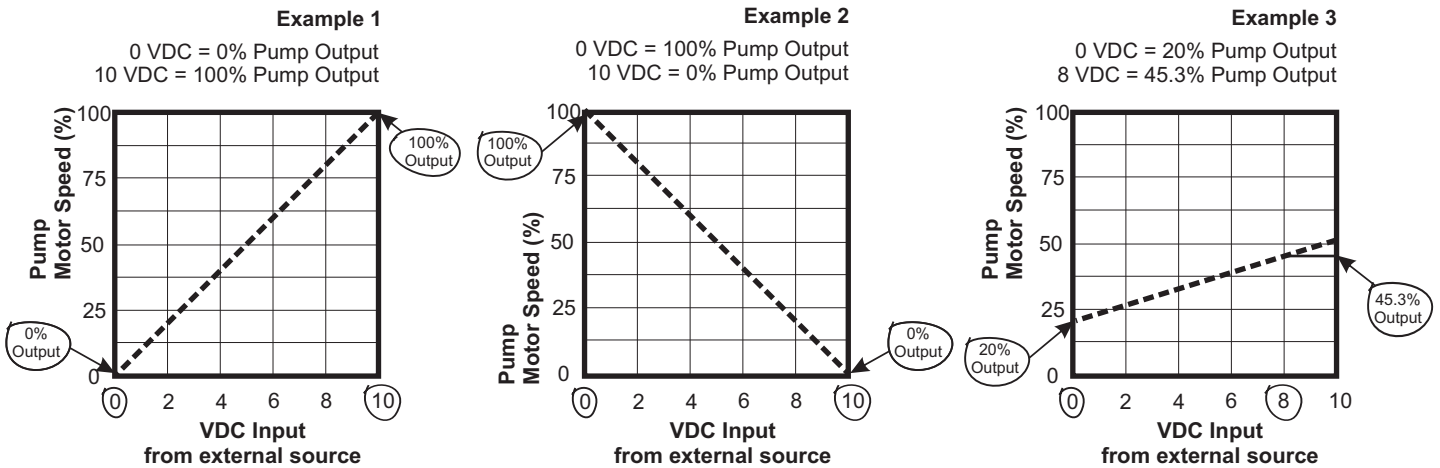
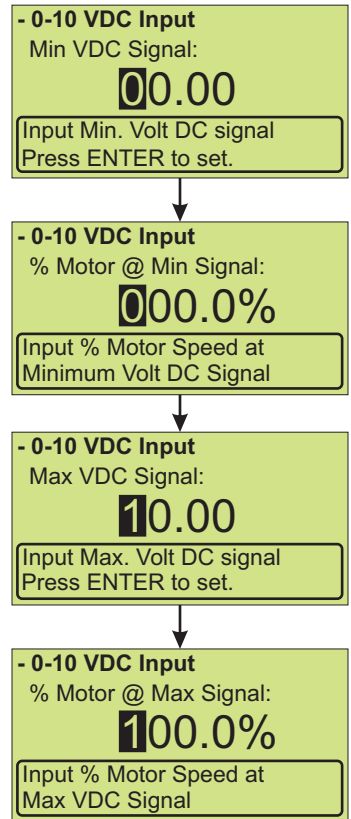

Tip!

In 0 - 10 VDC mode, you can view current incoming signal by pressing RIGHT arrow (see screen shot). RIGHT arrow is a convenient way to scroll through multiple read-only screens during normal operating mode of pump.

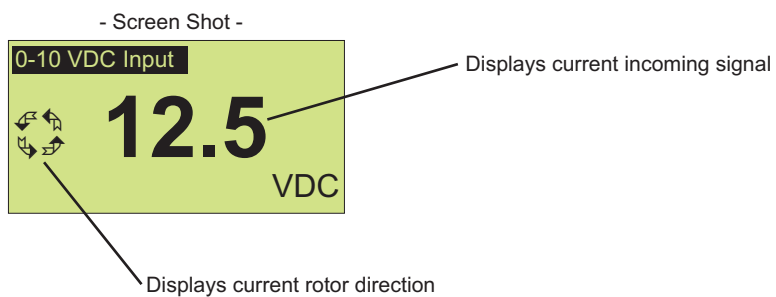

10.4 Frequency Input (Hz)

Used to remotely control pump with an incoming high speed frequency signal. Typically used with flow meters or other external devices.

Default settings: 0 Frequency (Hz) = 0% motor speed
1000 Frequency (Hz) = 100% motor speed

Navigate to **Frequency Input** menu by using short-cut method described at beginning of section, or by pressing MENU button, then selecting Input Setup, Input Modes, and then **Frequency Input**.

Press UP or DOWN arrow to scroll through 0 - 9 on selected digit.

Press RIGHT arrow to scroll over to next digit to right. If you pass your desired digit, you can easily scroll back by continuously pressing RIGHT button.

Press ENTER to save changes.

Continue this process until all four screens have been configured.

If you used short-cut to enter Frequency Input setup, then just press and hold Select Run Mode button until Run Mode screen is displayed.

If you used Menu button to navigate to Frequency Input setup, you must navigate back out of menu structure. To do this you must select <-Esc at bottom of every screen menu until you see Run Mode screen displayed.

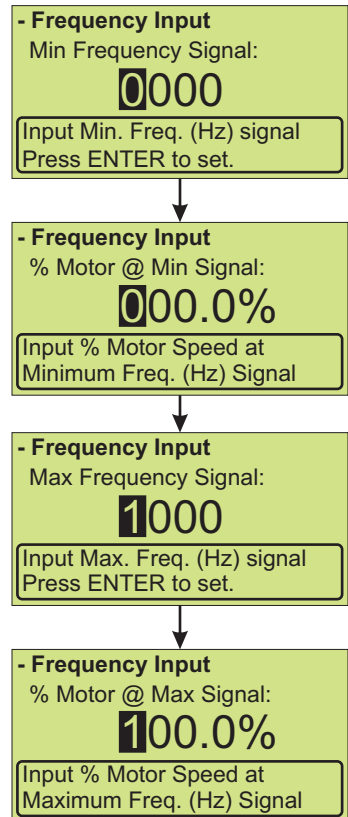

Examples:

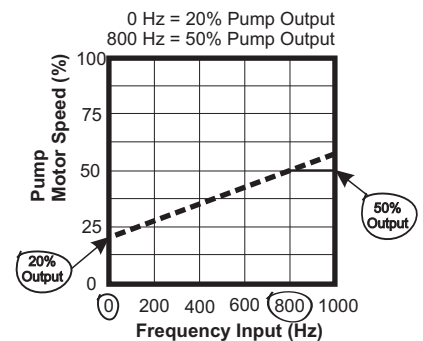
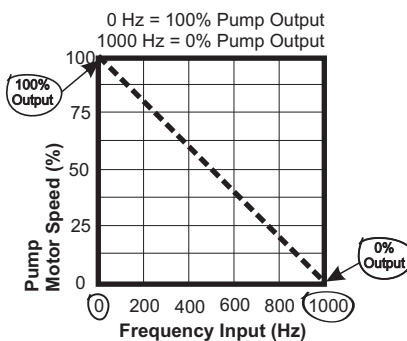
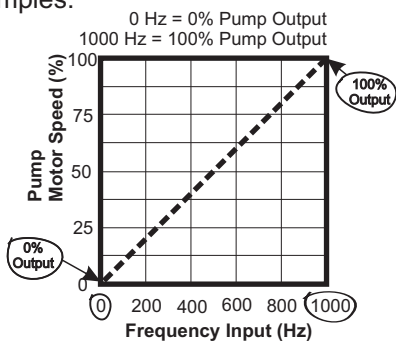

Example #1, Ultrasonic flow meter

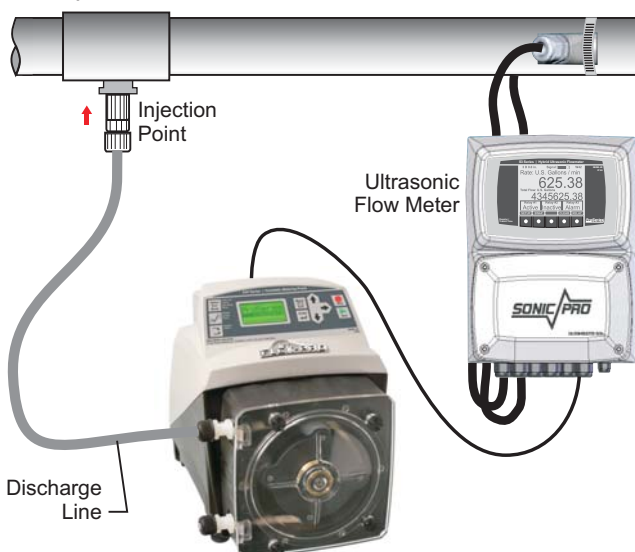

Example #2, Paddlewheel flow meter

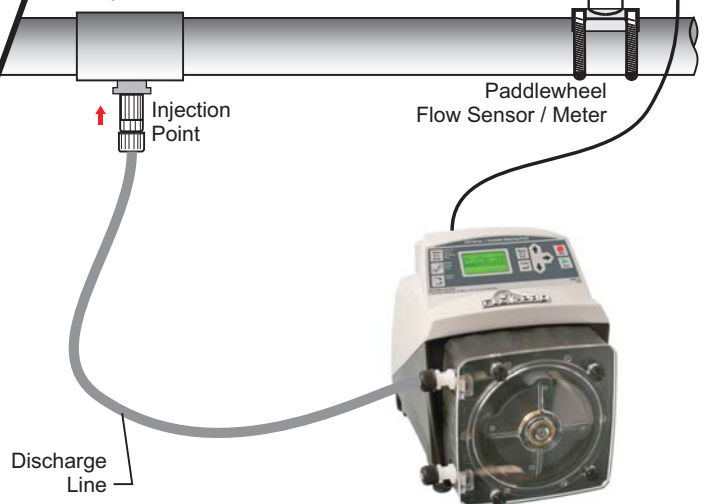

Tip!



In Frequency Input mode, you can view current incoming signal by pressing RIGHT arrow (see screen shot). RIGHT arrow is a convenient way to scroll through multiple read-only screens during normal operating mode of pump.

- Screen Shot -

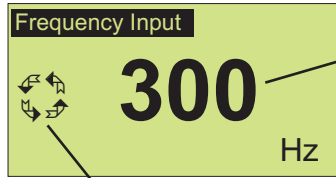

Displays current incoming signal

Displays current rotor direction

10.5 Pulse Batch (low speed pulse)

Used to remotely control pump with an incoming pulse signal. Can be used with an external foot pedal, a water meter, a PLC, contact closure, or other low speed pulse devices.

Default settings: 1 Pulse = 100% motor speed for 2.5 seconds

Navigate to **Pulse Batch** menu by using short-cut method described at beginning of section, or by pressing MENU button, then selecting Input Setup, Input Modes, and then **Pulse Batch**.

Press UP or DOWN arrow to scroll through 0 - 9 on selected digit.

Press RIGHT arrow to scroll over to next digit to right. If you pass your desired digit, you can easily scroll back by continuously pressing RIGHT button.

Press ENTER to save changes.

Continue this process until all four screens have been configured.

If you used short-cut to enter Pulse Batch setup, then just press and hold Select Run Mode button until Run Mode screen is displayed.

If you used Menu button to navigate to Pulse Batch setup, you must navigate back out of menu structure. To do this you must select <-Esc at bottom of every screen menu until you see Run Mode screen displayed.

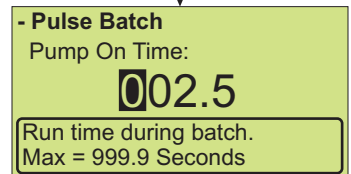
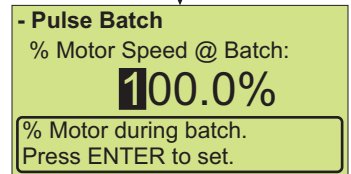
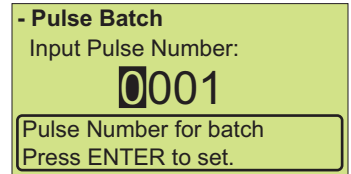

Tip!



In Pulse Batch mode, you can view current incoming signal count by pressing RIGHT arrow (see screen shot). RIGHT arrow is a convenient way to scroll through multiple read-only screens during normal operating mode of pump.

- Screen Shot -

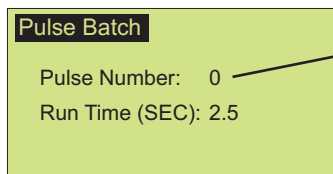

Displays current incoming signal

10.6 Manual Cycle Adjust (repeating cycle timer)

Used to run at a pre-selected motor speed for a specified run time. This cycle will repeat itself using a repeating cycle timer.

Default settings: 100% motor speed for 1.5 seconds
Repeating cycle timer = 4 seconds

Navigate to **Manual Cycle Adjustment** menu by using short-cut method described at beginning of section, or by pressing MENU button, then selecting Input Setup, Input Modes, and then **Cycle Adjustment**.

Press UP or DOWN arrow to scroll through 0 - 9 on selected digit.

Press RIGHT arrow to scroll over to next digit to right. If you pass your desired digit, you can easily scroll back by continuously pressing RIGHT button.

Press ENTER to save changes.

Continue this process until all three screens have been configured.

If you used short-cut to enter Manual Cycle Adjustment setup, then just press and hold Select Run Mode button until Run Mode screen is displayed.

If you used Menu button to navigate to Cycle Adjustment setup, you must navigate back out of menu structure. To do this you must select <-Esc at bottom of every screen menu until you see Run Mode screen displayed.

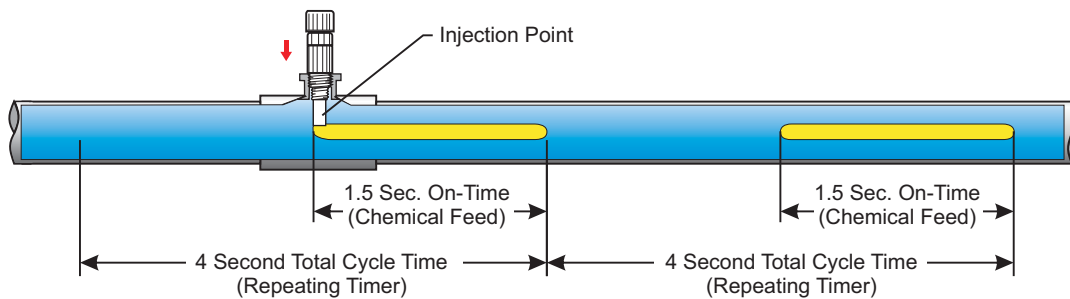
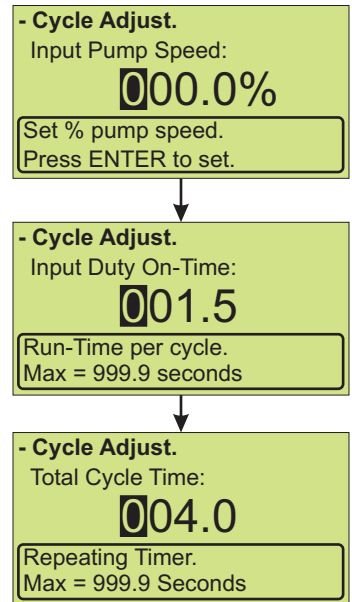

Graphical representation of Manual Cycle Adjust injection characteristics.

Note: Your chemical or solution is mixed in fluid. This image is only illustrating feed characteristics.

Tip!



In Manual Cycle Adjust mode, you can view current settings by pressing RIGHT arrow (see screen shot). RIGHT arrow is a convenient way to scroll through multiple read-only screens during normal operating mode of pump.

- Screen Shot -

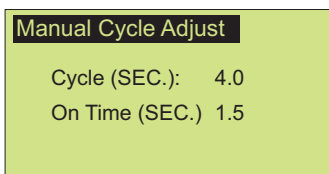

10.7 Dispensing

Configure any dispensing amount or sample size and pump will repeat it on command by pressing START button. Great for accurate single shot dispensing of a pre-configured volume.

Default settings: 1000 milliliters
 50% pump speed

Navigate to **Dispensing** menu by using short-cut method described at beginning of section, or by pressing MENU button, then selecting Input Setup, Input Modes, and then **Dispensing**.

Press UP or DOWN arrow to scroll through 0 - 9 on selected digit.

Press RIGHT arrow to scroll over to next digit to right. If you pass your desired digit, you can easily scroll back by continuously pressing RIGHT button.

Press ENTER to save changes.

Continue this process until all two screens have been configured.

If you used short-cut to enter Dispensing setup, then just press and hold Select Run Mode button until Run Mode screen is displayed.

If you used Menu button to navigate to Dispensing setup, you must navigate back out of menu structure. To do this you must select <-Esc at bottom of every screen menu until you see Run Mode screen displayed.

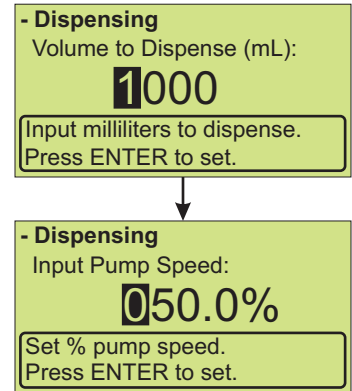

Tip!



In Dispensing mode, you can view current incoming signal count by pressing RIGHT arrow (see screen shot). RIGHT arrow is a convenient way to scroll through multiple read-only screens during normal operating mode of pump.

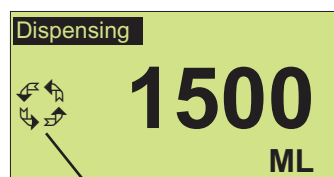

Displays current rotor direction

10.8 Manual Dosing

Used to configure Parts Per Million dosing to a system. This method can be used if treated fluid volume is a fixed amount (in Liters Per Minute). If treated fluid volume is variable (continuous change), then use of a flow meter is recommended along with pumps Proportional Mode (next Run Mode).

Default settings: 12.5% dose solution concentration
1.25 dose solution Specific Gravity
10 LPM (liters per minute) fluid volume to be treated
1.0 Parts Per Million to dose

Navigate to **Manual Dosing** menu by using short-cut method described at beginning of section, or by pressing MENU button, then selecting Input Setup, Input Modes, and then **Manual Dosing**.

Press UP or DOWN arrow to scroll through 0 - 9 on selected digit.

Press RIGHT arrow to scroll over to next digit to right. If you pass your desired digit, you can easily scroll back by continuously pressing RIGHT button.

Press ENTER to save changes.

Continue this process until all four screens have been configured.

If you used short-cut to enter Manual Dosing setup, then just press and hold Select Run Mode button until Run Mode screen is displayed.

If you used Menu button to navigate to Manual Dosing setup, you must navigate back out of menu structure. To do this you must select <-Esc at bottom of every screen menu until you see Run Mode screen displayed.

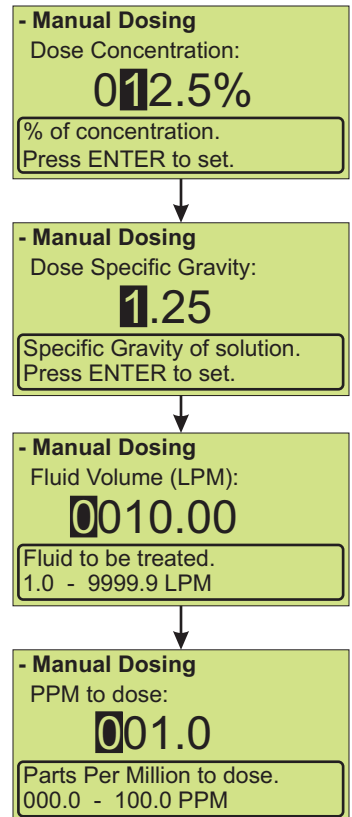

Tip! 

In Manual Dosing mode, you can view current settings by pressing RIGHT arrow (see screen shot). RIGHT arrow is a convenient way to scroll through multiple read-only screens during normal operating mode of pump.

- Screen Shot -

Manual Dosing	
% Concentration:	12.5
Spec. Gravity:	1.25

10.9 Proportional Dosing

Used to configure proportional Parts Per Million dosing to a system. This method of proportional dosing is based off input pump is receiving from an external flow meter. Flow meter must have a pulse output. You will need to refer to flow meter instruction manual to obtain K-factor for flow meter.

Default settings: 12.5% dose solution concentration
 1.25 dose solution Specific Gravity
 5.0 K-factor (Pulses Per Liter), see flow meter instruction manual
 1.0 Parts Per Million to dose

Navigate to **Proportional Dosing** menu by using short-cut method described at beginning of section, or by pressing MENU button, then selecting Input Setup, Input Modes, and then **Proportional**.

Press UP or DOWN arrow to scroll through 0 - 9 on selected digit.

Press RIGHT arrow to scroll over to next digit to right. If you pass your desired digit, you can easily scroll back by continuously pressing RIGHT button.

Press ENTER to save the changes.

Continue this process until all four screens have been configured.

If you used short-cut to enter Proportional Dosing setup, then just press and hold Select Run Mode button until Run Mode screen is displayed.

If you used Menu button to navigate to Proportional Dosing setup, you must navigate back out of menu structure. To do this you must select <-Esc at bottom of every screen menu until you see Run Mode screen displayed.

- Proportional Dosing
 Dose Concentration:
012.5%
 Percentage of concentration.
 Press ENTER to set.

↓

- Proportional Dosing
 Dose Specific Gravity:
1.25
 Specific Gravity of solution.
 Press ENTER to set.

↓

- Proportional Dosing
 Input K-Factor (pulses):
0005.0000
 Pulses Per Liter.
 0.0001 - 9999.9999

↓

- Proportional Dosing
 PPM to dose:
001.0
 Parts Per Million to dose.
 000.0 - 100.0 PPM

Example #1, Ultrasonic flow meter

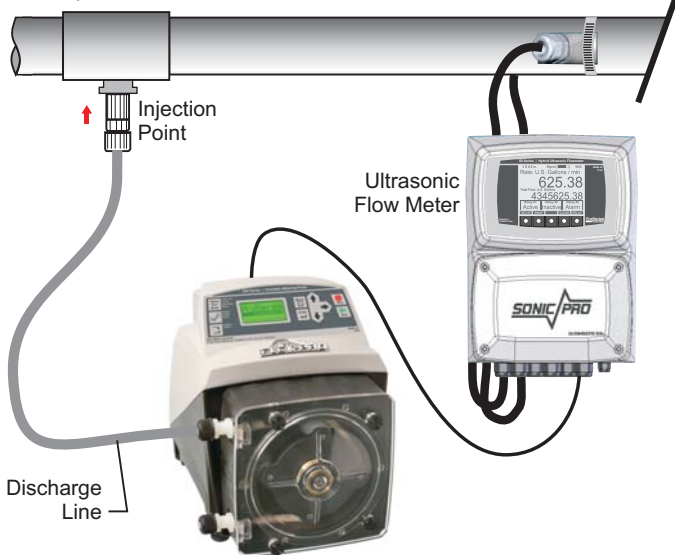

or

Example #2, Paddlewheel flow meter

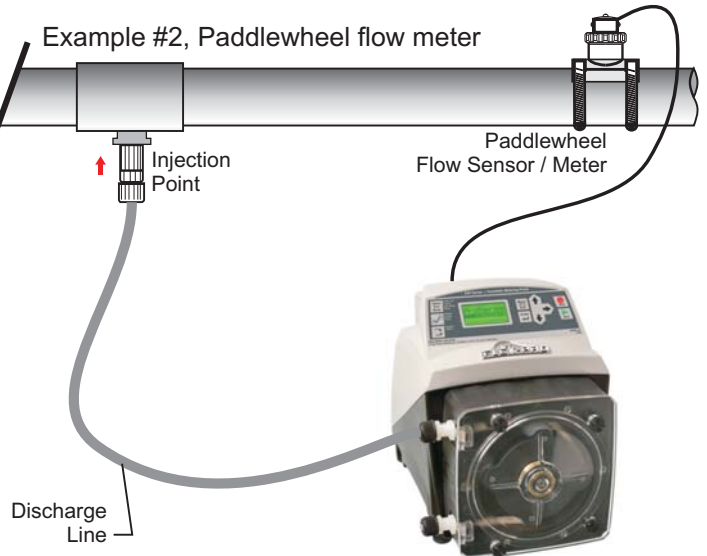

Tip!



In Proportional Dosing mode, you can view current incoming signal count and settings by pressing RIGHT arrow (see screen shots). RIGHT arrow is a convenient way to scroll through multiple read-only screens during normal operating mode of pump.

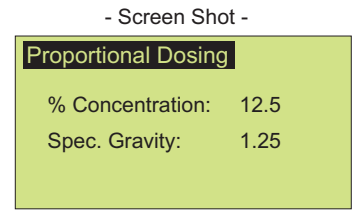
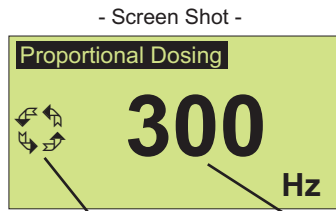

Displays current rotor direction
Displays current incoming signal

11.0 Contact Closure Input

Used to remotely start and stop pump using a close=stop or open=stop signal. If pump should start on an open, then select "Close: Stop Pump" option. Can be used with an external foot pedal, a PLC, contact closure, or other similar external devices.

Default settings: Disable

CC Input Range: 6 - 30 VDC
or
Dry Contact Closure (no voltage required)
[See section 14.0 for wire connections]

Navigate to **Contact Input** menu by MENU button, then selecting Input Setup, and then **Contact Input**.

Press UP or DOWN arrow to scroll through your options.

Press ENTER to make a selection. You should then notice radio button (square box) is now filled in next to your selection.

Press DOWN arrow to scroll down to Done selection. Then press ENTER.

To navigate back out of menus, select <-Esc and press the ENTER button at bottom of every screen menu until you see Run Mode screen displayed.

IMPORTANT: If Contact Closure Input is enabled, pump will display STANDBY if pump is in Stop mode via the Contact Closure. **Please use caution in this mode. Pump can Start at anytime. If you must perform maintenance to the pump, Press STOP button.**

When Contact Closure Input is enabled, the word **Remote** will be displayed on lower left side of screen at all times.

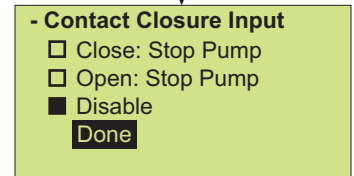
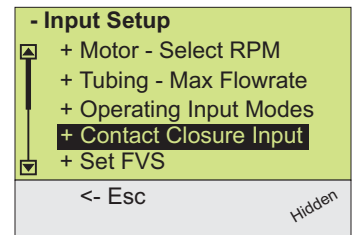
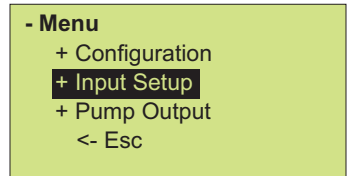

- Sample Screen Shots -

Signal stopped pump

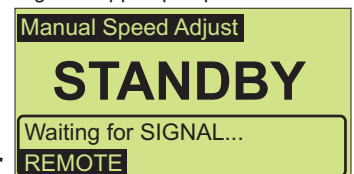

Signal started pump

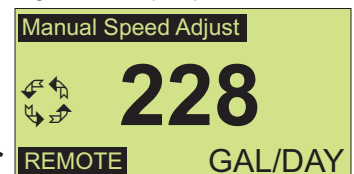

12.0 Set FVS (Flow Verification System)

Used to monitor pump output. If pump does not dispense fluid when pump head rotor is turning, pump will go into an alarm mode and stop pump. Blue-White offers a flow verification sensor that can easily attach to fitting on pump.

Default settings: 000 (off)

Navigate to **Set FVS** menu by pressing MENU button, then selecting Input Setup, and then **Set FVS**.

Press UP or DOWN arrow to scroll through 0 - 9 on selected digit.

Press RIGHT arrow to scroll over to next digit to right. If you pass your desired digit, you can easily scroll back by continuously pressing RIGHT button.

Press ENTER to save changes and exit FVS screen.

To navigate back out of menus, select <-Esc and press ENTER button at bottom of every screen menu until you see Run Mode screen displayed.

Flow Verification System (sensor sold separately)

A3 is equipped with a *Flow Verification System* which is designed to stop pump and provide a contact closure output or 10 amp relay output (setup in software) in event sensor does not detect chemical during pump operation. This could indicate a clogged injection fitting, empty chemical solution tank, worn pump tube, loose tubing connection, etc.

To allow pump to clear any gasses that may have accumulated during stopper operation (such as with chlorine), an alarm delay time value from 1-255 seconds must be programmed (An alarm delay value of 000 seconds disables FVS system).

If FVS alarm occurs, pump will stop, send an external signal (if setup), and screen will flash FVS with an alarm icon.

To clear FVS alarm, you must press START button or re-cycle power (unplug power to pump, then plug back in).

Install FVS Flow Sensor - Flow Verification Sensor (FVS) should be installed on the inlet (suction) side of the pump tube. Sensor includes a PVC tubing insert, located inside sensors female thread connection, that is designed to seal sensor onto pump tube inlet adapter. Thread sensor onto pump tube until tubing insert is snug against pump tube inlet fitting - do not over-tighten.

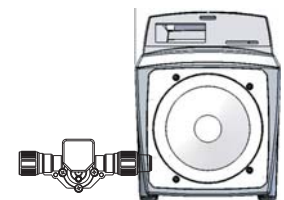
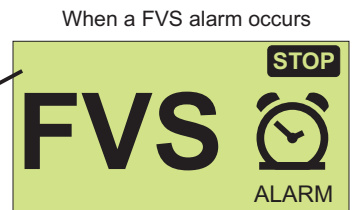
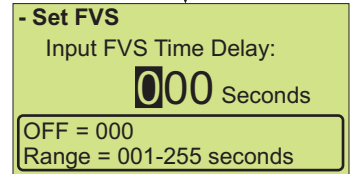
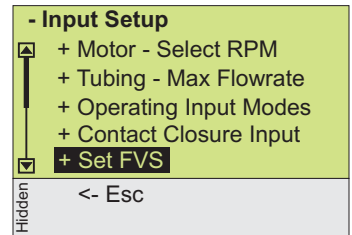

Confirm the FVS flow range - Flow Verification Sensor (FVS) will only function within its operating range. Sensor model FV-100-6V has an operating range of 30-300 ml/min (1-10 oz/min). If the pump's output is less than 30 ml/min (0.5 ml/sec), sensor will not detect chemical and a signal will not be sent to pump.

SENSOR MODEL NUMBER	OPERATING FLOW RANGE (ml/min)
FV-200-6V	100-1000
FV-300-6V	200-2000
FV-400-6V	300-3000
FV-500-6V	500-5000
FV-600-6V	700-7000

13.0 Output Setup

Below is menu structure for Output Setup selection.

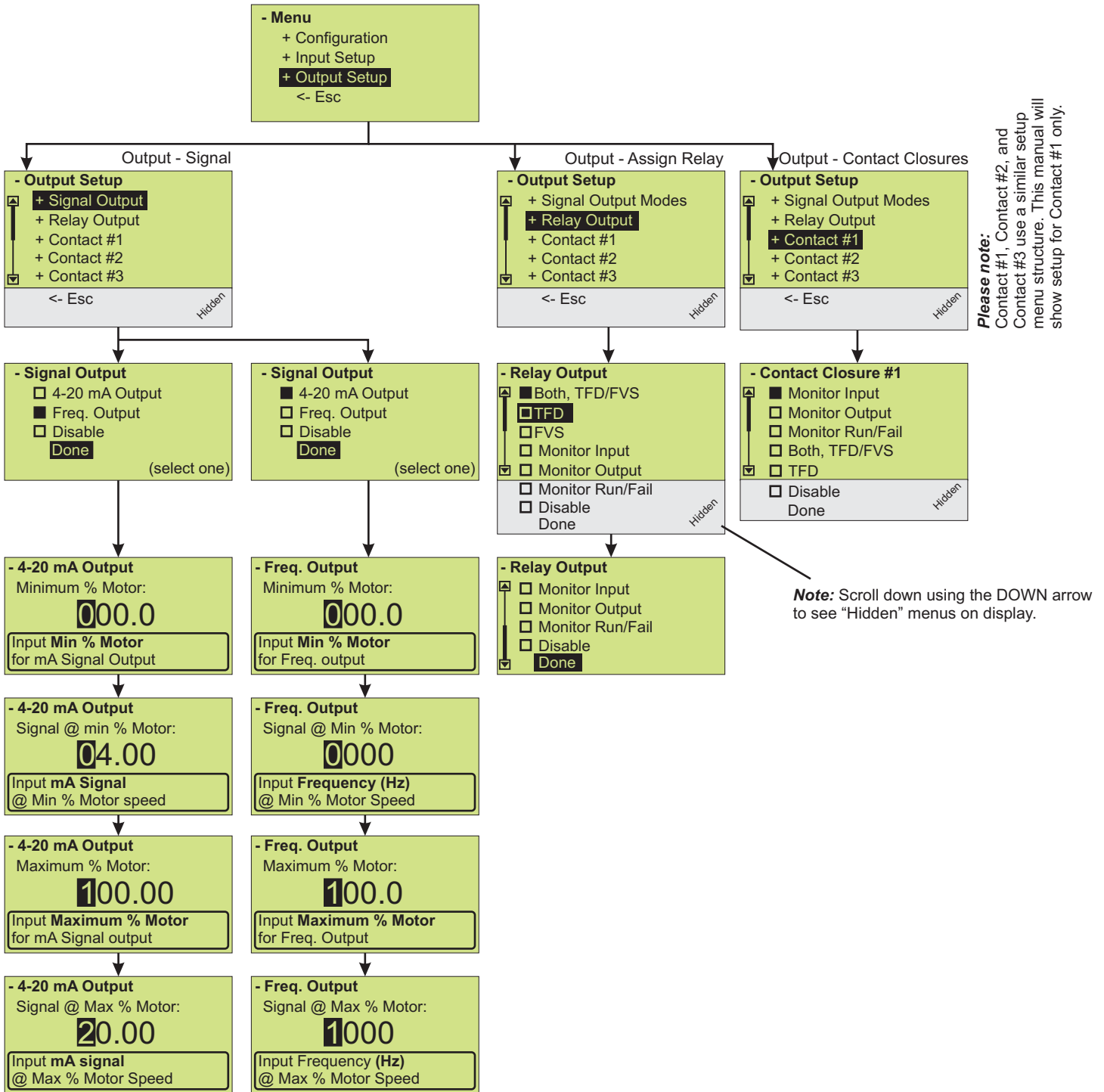

Output Setup

Layout of Output Setup menu is similar to Input Setup menu. Outputs were designed to directly communicate to SCADA systems, alarms, data loggers, backup pumps, pumps to operate in sync, pumps to operate proportionally, and other external devices.

13.1 Signal Output

Sends a configurable 4 - 20 mA or frequency (Hz) signal to another pump or external device. This feature can be used to control other pumps (in sync / proportionally), data logging systems, and other external devices for plant automation.

Default settings: Disable

Navigate to **Signal Output** menu by pressing MENU button, then selecting Output Setup, and then **Signal Output**.

Select your desired Signal output using UP or DOWN arrows.

Press ENTER to configure output signal.

Press UP or DOWN arrow to scroll through 0 - 9 on selected digit.

Press RIGHT arrow to scroll over to next digit to right. If you pass your desired digit, you can easily scroll back by continuously pressing RIGHT button.

Press ENTER to save changes.

Continue this process until all four screens have been configured.

To navigate back out of menu structure you must select <-Esc at bottom of every screen menu until you see Run Mode screen displayed.

Example 1

0% Pump Output = 4 mA
100 % Pump Output = 20 mA

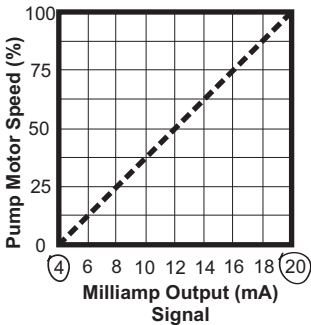

Example 2

0% Pump Output = 4 mA
50% Pump Output = 16 mA

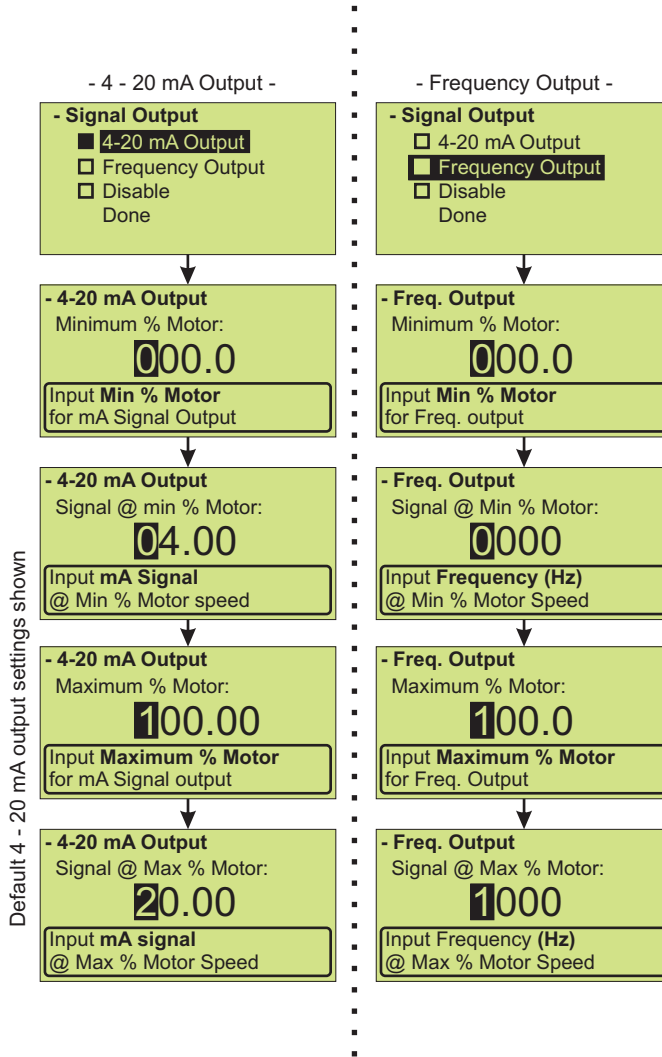
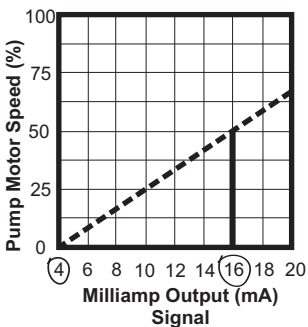

Example 1

0% Pump Output = 0 Hz
100 % Pump Output = 1000 Hz

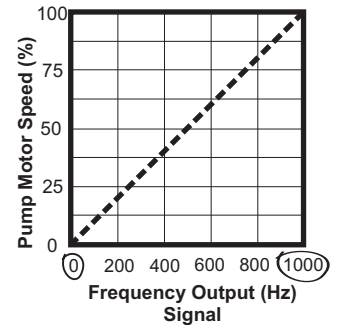

Example 2

0% Pump Output = 1000 Hz
100% Pump Output = 0 Hz

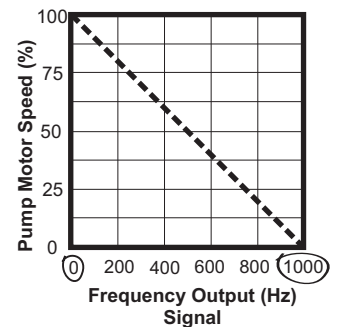

14.0 External Signal Connections

A3V will accept many types of external inputs. 4-20mA and 0-10 VDC loops must be powered. Two types of frequency inputs, AC sine waves (magnetic coils type outputs) and Digital Square waves (Hall Effect signals, contact closures), are acceptable.



Disconnect power from the pump before removing the junction box cover.

All wiring connections are to be made inside of the junction box located on back of the A3. Junction box cover is secured to junction box by four stainless steel 10-32 round head phillips screws. Liquid tight connectors are supplied and should be used for external signal cable. Signal wiring is color coded and/or printed to identify signal type.

Loosen cap end of liquid tight connector and remove plug that ships with pump. Feed input / output wires through liquid tight connector. Suitable cable must be passed into junction box through one or more liquid tight connectors and connected appropriately. Tighten liquid tight connectors to ensure a NEMA 4X seal.

All signal wire ends are dipped in a non-conductive plastic to prevent contact with enclosure and/or other wires. Ensure no bare wires come in contact with enclosure.

Signal Input Wire Bundle Color Codes

Five wire input bundle



Input Signal Type	Wire Color Code	Input Mode (run mode)
4-20 mA	BLUE (+) [non-powered] & BLACK (-)	4-20 mA Input
0-10 VDC	ORANGE (+) [non-powered] & BLACK (-)	0-10 VDC Input
Frequency, AC sine wave, TTL, CMOS	WHITE (+) & BLACK (-)	Frequency Input, Pulse Batch, or Proportional Dosing
Contact (10V @ 2 mA max.) Hall Effect, NPN	RED (+) & WHITE (-)	Frequency Input, Pulse Batch, or Proportional Dosing

Input - Flow Verification Sensor (FVS)

Used to monitor pump output (chemical feed).
FVS sensor sold separately.
Cable is labeled: **INPUT FVS**



FVS Input Wire Connections

RED / WHITE (+15 VDC)
BLACK (-)
YELLOW (signal)

Input - Remote Start / Stop

Perfect for use with a PLC to control chemical feed.
Great for footswitch or similar remote input.
Cable is labeled: **INPUT REMOTE**



Powered Contact Closure:

RED (+)
BLACK (-)
Required input voltage range: 6-30 VDC

Dry Contact Closure:

RED
BARE
No voltage required in this configuration.

Output - Analog 4-20 mA

Used to send a fully configurable (See **signal output** section 13.1) 4-20 mA output to an external device.
Cable is labeled: **Output 4-20**

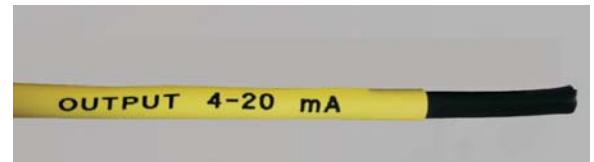

4-20 mA Output Wire Connections

RED (+)
BLACK (-)
BARE = Shield (not used)

Output - Frequency Open Collector Output

Used to send a fully configurable (See **signal output** section 13.1) 0-1000 Hz output to an external device.
Cable is labeled: **OUTPUT FREQ**



0-1000 Hz Output Wire Connections

RED (+)
BLACK (-)
BARE = Signal
A pull up resistor is required. Typical resistor = 1.5K ohms

Output - Relay, 10 Amp

Used to send up to a 10 Amp signal to an external device.
Works with AC or DC devices (see below).
Cable is labeled: **OUTPUT RELAY**



10 Amp Relay Output

Normally Open (NO) [Factory Default] or Normally Closed (NC)
10 Amp maximum @ 125 VAC
8 Amp maximum @ 30 VDC

Output - Contact Closure (1, 2, & 3)

Great for remote startup of a backup pump triggered by TFD.
Contact Closures are fully configurable (see section 13.0).
Cable is labeled: **OUTPUT CC1, CC2, CC3**





Contact Closure Output

Normally Open (NO) [Factory Default] or Normally Closed (NC)
1 Amp maximum @ 125 VAC
0.80 Amp maximum @ 30 VDC

15.0 Tube Replacement

For your safety, pump rotor will rotate at a maximum of 6 RPM while pump head cover is removed.

CAUTION 	Prior to service, pump clean water through the pump and suction / discharge line to remove chemical.
CAUTION 	Always wear protective clothing, face shield, safety glasses and gloves when working on or near your metering pump. Additional precautions should be taken depending on solution being pumped. Refer to MSDS precautions from your solution supplier.

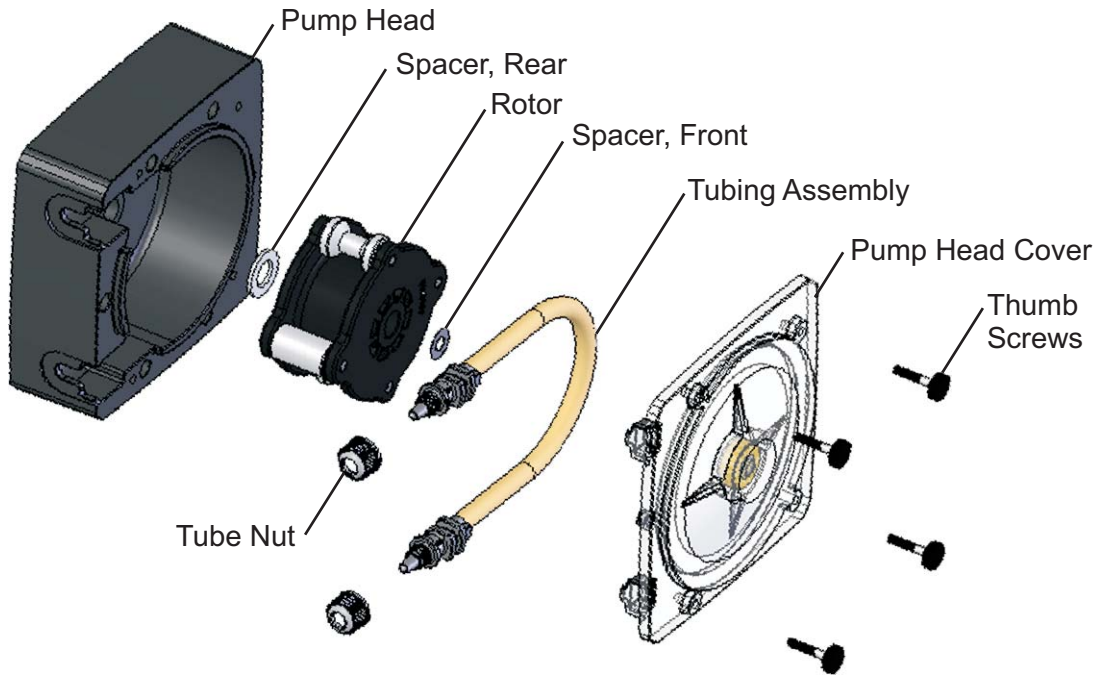

Remove **Pump Head Cover** by unscrewing four **Thumb Screws**. Pull out **Pump Head Cover**.

Pump will detect **Pump Head Cover** is removed and enter MAINTENANCE MODE.

Rotor will rotate at a maximum of 6 RPM for your safety.

Pull out suction side of **Tubing Assembly**.

Press START button. While rotor is rotating, pull out old **Tube Assembly**.

TIP! Let pump do the work for you. Just guide tubing out between two rollers located on **Rotor**.

Press STOP button at any time to stop the pump.

Pull out suction line adapter from Pump Head. Pull out **Tubing Assembly** as the **Rotor** rotates around.

Stop pump by pressing STOP button.

Thoroughly clean **Pump Head** and **Rotor**. **Rotor** can be removed by pulling straight out. After cleaning process, push **Rotor** back on shaft. See drawing above for proper assembly. IMPORTANT! **Rotor** direction; the word "FRONT" on **Rotor** must face front of pump.

Locate your new tubing and Tube Installation Tool. Please see next page on how to install new **Tube Assembly** into **Pump Head**.

MAINTENANCE MODE

Pump Cover Removed!

MAINTENANCE MODE

- Cover was removed!
- Motor Speed = 6 RPM

Press START to run
Press STOP to stop

! Use provided Tube Installation Tool to leverage tubing into pump head, NOT YOUR FINGERS.

! Use extreme caution when replacing pump tube. Be careful of your fingers and DO NOT place fingers near rollers.

For your safety, pump rotor will rotate at a maximum of 6 RPM while pump head cover is removed.

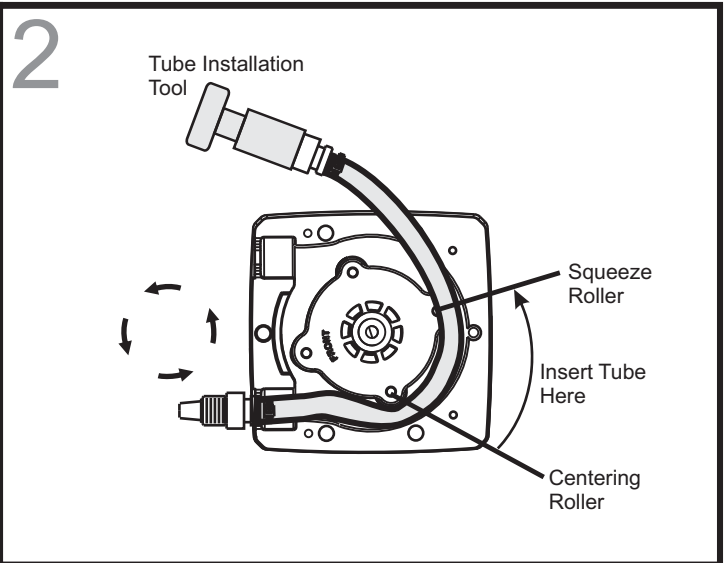
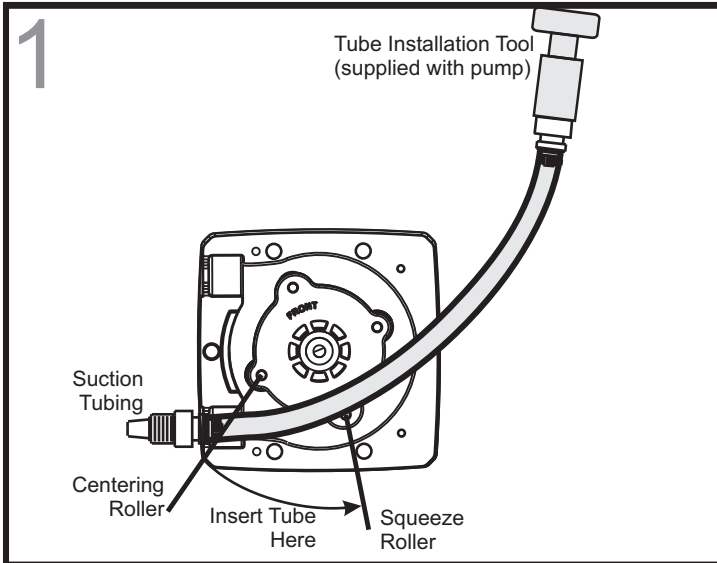

Use provided Tube Installation Tool.
First, position rotor so tubing will enter between a centering roller and squeeze roller. Insert suction fitting into pump head. Remove your fingers from pump head. Hold on to Tube Installation Tool. Start pump by pressing START button. Introduce tubing into pump head after a squeeze roller and before centering roller.

Use provided Tube Installation Tool.
While rotor is rotating, insert tubing between squeeze roller and centering roller. Continue this while rotor is rotating. Stop pump at anytime by pressing STOP button. Start pump by pressing START button.

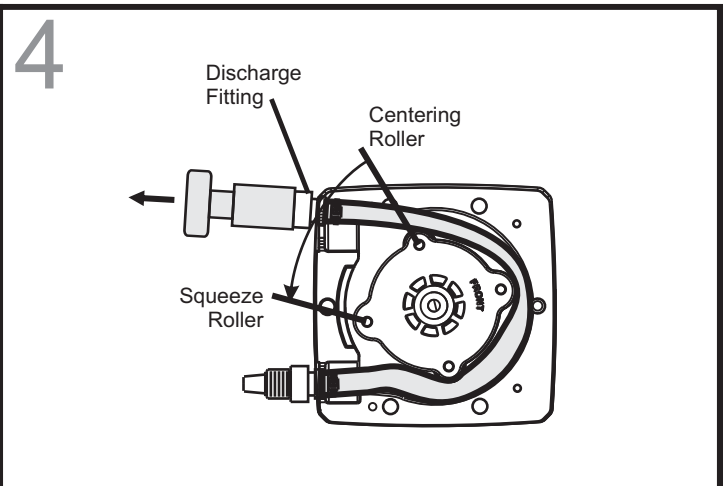
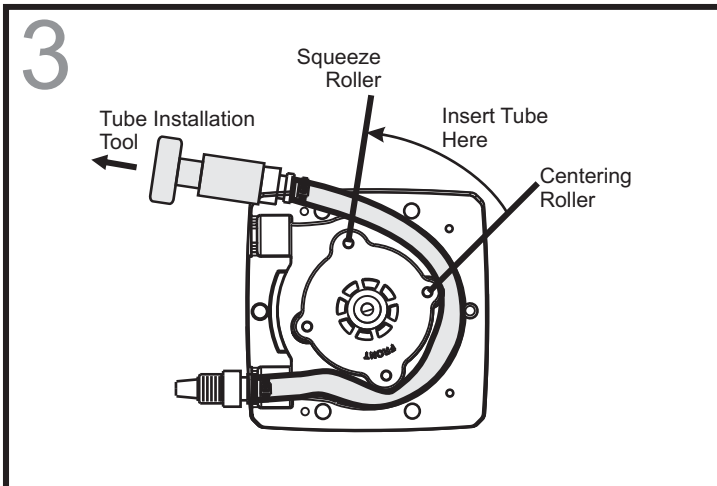

Use provided Tube Installation Tool.
Continue to follow rotation of rotor while directing tube into pump head. At this point, you may need to pull Tube Installation Tool to stretch tubing into position. Tube may not be stretched enough to insert discharge fitting. Let rotor spin a few rotations while pulling Installation tool so fitting can be properly installed.

Continue to pull Tube Installation Tool to allow enough room to slide discharge fitting into pump head tongue and groove. Once discharge fitting is secured in pump head, stop pump by pressing STOP button. Pump will ask you if you'd like to reset tube timer. If you choose **yes**, current tube time will display for 5 seconds before resetting to zero. Make note of your displayed tube life, then select **yes**. This will reset tube timer to zero.

Re-attach **Pump Head Cover** using the four **Thumb Screws**.

Pump will detect **Pump Head Cover** is installed and begin to exit MAINTENANCE MODE.

Pump will ask you if Tube was replaced. Yes / No

If Yes is selected, pump ask you to reset Tube Timer. Yes / No

If Yes is selected, pump will display Current Tube Timer briefly (5 seconds) before resetting to zero.

The pump can now begin normal operation.

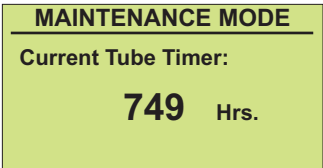
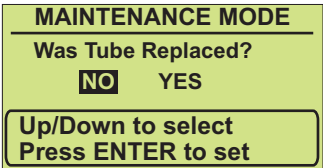
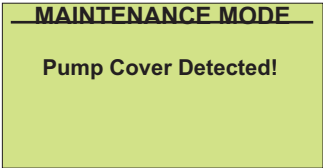

16.0 TFD (Tube Failure Detection)

A3V is equipped with a *Tube Failure Detection* System which is designed to stop pump and provide a contact closure output, 10 amp relay output, or both (see Output menu) in the event pump tube should rupture and chemical enters pump head. This patented system is capable of detecting presence of a large number of chemicals including Sodium Hypochlorite (Chlorine), Hydrochloric (muriatic) Acid, Sodium Hydroxide, and many others. System will not be triggered by water (rain, condensation, etc.) or silicone oil (roller and tubing lubricant).

If system has detected chemical, pump tube must be replaced and pump head and roller assembly must be thoroughly cleaned.

If TFD alarm occurs, pump will stop, send an external signal (if setup), and screen will flash TFD with an alarm icon.

To see total pump run time on your tubing:

Press STOP button to exit TFD alarm mode.

Press DOWN button and ENTER button at same time. This will display hours of run time with your currently installed tubing. You can use this feature to check your current tube run time at any time of normal pump operation.

For instruction on how to remove ruptured tubing - Please see **section 15.0**

Confirm Chemical Detection - To determine if your chemical will be detected by system, remove pump tube and roller assembly. Place a small amount of chemical in bottom of pump head - just enough to cover sensors. Turn on pump. If TFD system detects chemical, pump will stop after a two second confirmation period and TFD Alarm screen will display. If TFD system does not detect chemical, pump will continue to run after confirmation period. Carefully clean chemical out of pump head being sure to remove all traces of chemical from sensor probes. Press START button to clear alarm condition and restart pump

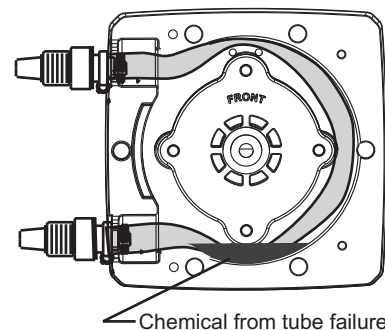

When a TFD alarm occurs

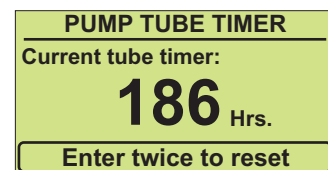

17.0 Pump Tube Timer

A3V has a built in Pump Tube Timer. Timer starts when rotor is rotating and stops when rotor is idle.

To view current Pump Tube Timer, press ENTER and DOWN arrow at same time.
Note: Pump must be in normal operating mode (not configuration mode) to view timer.

Screen will display current Pump Tube Time in run-time hours.

Pump Tube Timer will display for 5 seconds, then switch back to previous operating screen.

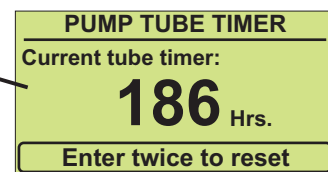

Caution: Press ENTER button twice to reset Pump Tube Timer to zero.

When replacing pump tube, pump will ask you if you'd like to reset Pump Tube Timer. If you choose YES, screen will display current Pump Tube Time for 5 seconds before timer is reset to zero.



18.0 Reverse Rotor Rotation

Increase tube life with this feature!

<p>CAUTION</p> 	<p>Prior to service, pump clean water through the pump and suction / discharge line to remove chemical.</p>
<p>CAUTION</p> 	<p>Always wear protective clothing, face shield, safety glasses and gloves when working on or near your metering pump. Additional precautions should be taken depending on solution being pumped. Refer to MSDS precautions from your solution supplier.</p>

Pump rotor can reverse rotation by pressing REVERSE ROTATION button. This process can be used for many reasons throughout various industries.

Two reasons for reversing current rotor rotation; to purge chemical from tubing and to extend tube life.

Plan ahead before reversing rotor rotation. If checkvalves are installed, make necessary arrangements to allow back flow.

<p>CAUTION</p> 	<p>Failure to install checkvalves in their proper flow direction can cause excess pressure (PSIg) build up in system and can result in tube rupture. Always use extreme caution and ensure proper connections when using this feature.</p>
---	--

If your desire is to simply extend tube life:

Typically tubing fails on outlet side (pressure side) of tube assembly in pump head.

Reversing rotation, moves outlet side (pressure side) to opposite side of tube assembly, greatly increasing tube life.

Stop pump before tube failure occurs.



Disconnect power from pump. Carefully purge any pressure in discharge line of pump. Disconnect suction end tubing and discharge end tubing from pump head tubing.

IMPORTANT! Swap sides of suction (inlet) and discharge (outlet) tubing. No need to remove Pump Head Cover.

Double check all connections before starting pump.

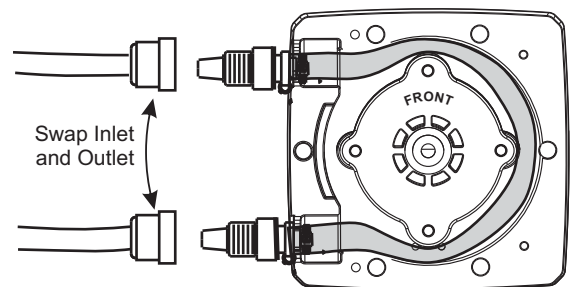
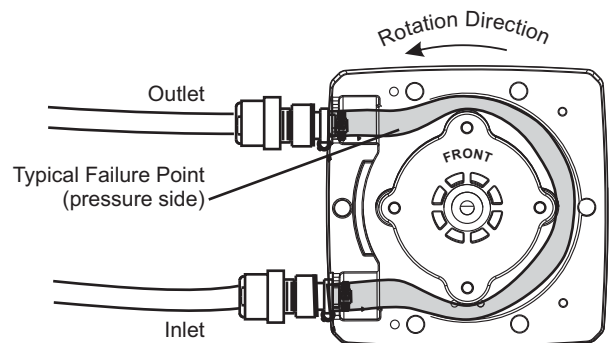

19.0 How to Maintain Pump

CAUTION

Always wear protective clothing, face shield, safety glasses and gloves when working on or near your metering pump. Additional precautions should be taken depending on solution being pumped. Refer to MSDS precautions from your solution supplier.

Routine Inspection and Maintenance

Pump requires very little maintenance. However, pump and all accessories should be checked weekly. This is especially important when pumping chemicals. Inspect all components for signs of leaking, swelling, cracking, discoloration or corrosion. Replace worn or damaged components immediately.

Cracking, crazing, discoloration and the like during first week of operation are signs of severe chemical attack. If this occurs, immediately remove chemical from pump. Determine which parts are being attacked and replace them with parts that have been manufactured using more suitable materials. Manufacturer does not assume responsibility for damage to pump that has been caused by chemical attack.

How to Clean and Lubricate Pump

Pump will require occasional cleaning. The amount will depend on severity of service.

☞When changing pump tube assembly, pump head chamber, roller assembly and pump head cover should be wiped free of any dirt and debris.

☞Pump head cover bearing may require grease periodically. Apply a small amount of grease (Aeroshell aviation grease #5 or equivalent) when necessary.

☞Although not necessary, 100% silicon lubrication may be used on the roller assembly and tube assembly.

☞Periodically clean injection/check valve assembly, especially when injecting fluids that calcify such as sodium hypochlorite. These lime deposits and other build ups can clog fitting, increase the back pressure and interfere with check valve operation.

☞Periodically clean suction strainer.

20.0 Pump Head - Exploded View and Part Numbers

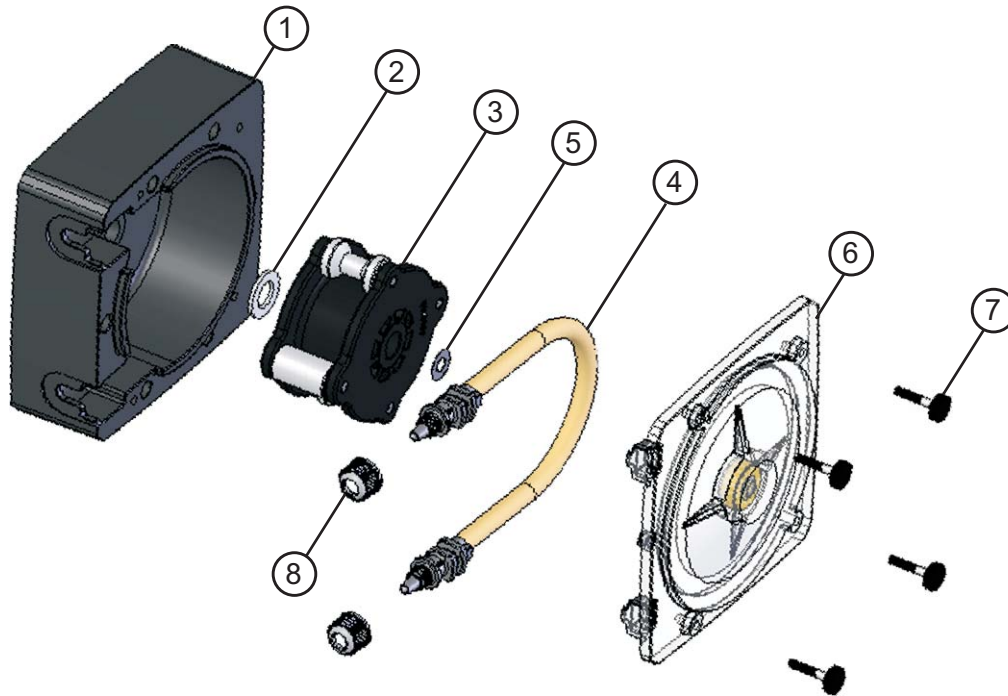

Item	Description	Part Number	Quantity
1	Pump Head	A3-SXX-H	1
2	Spacer, Back	90011-184	1

Group	All roller assemblies (rotors) in this group are same size and interchangeable.	3	Roller Assembly Complete (Rotor)	A3-SND-R	1
		4	Tube Assembly, Norprene (.075 ID), printed with ND	A3-SND-T	1
		3	Roller Assembly Complete (Rotor)	A3-SNF-R	1
		4	Tube Assembly, Norprene (.155 ID), printed with NF	A3-SNF-T	1

Group	All roller assemblies (rotors) in this group are same size and interchangeable.	3	Roller Assembly Complete (Rotor)	A3-SNH-R	1
		4	Tube Assembly, Norprene (.250 ID), printed with NH	A3-SNH-T	1
		3	Roller Assembly Complete (Rotor)	A3-SNJ-R	1
		4	Tube Assembly, Norprene (.312 ID), printed with NJ	A3-SNJ-T	1
		3	Roller Assembly Complete (Rotor)	A3-SNK-R	1
		4	Tube Assembly, Norprene (.375 ID), Printed with NK	A3-SNK-T	1

Group	All roller assemblies (rotors) in this group are same size and interchangeable.	3	Roller Assembly Complete (Rotor)	A3-SGE-R	1
		4	Tube Assembly, Tygothane (.125 ID), printed with GE	A3-SGE-T	1
		3	Roller Assembly Complete (Rotor)	A3-SGG-R	1
		4	Tube Assembly, Tygothane (.187 ID), printed with GG	A3-SGG-T	1
		3	Roller Assembly Complete (Rotor)	A3-SGH-R	1
		4	Tube Assembly, Tygothane (.250 ID), printed with GH	A3-SGH-T	1

5	Spacer, Front	90011-014	1
6	Pump Head Cover, Annealed Acrylic	A3-SXX-H	1
7	Thumb Screw	90011-186	4
8	Tube Nut, Compression, For 3/8" Tubing	C-330-6	2

Note: All Tube Assemblies have identification number printed directly on tubing.

Example: Printed NH, replacement Tube Assembly = A3-SNH-T, replacement Roller Assembly = A3-SNH-R

Replacement Tube Assembly and Roller Assembly (Rotor) part number explained:

Example Tube Assembly with "NH" printed on tubing:

N = Norprene
H = Tubing ID

Example Tube Assembly reorder number with NH printing:

A3-SNH-T

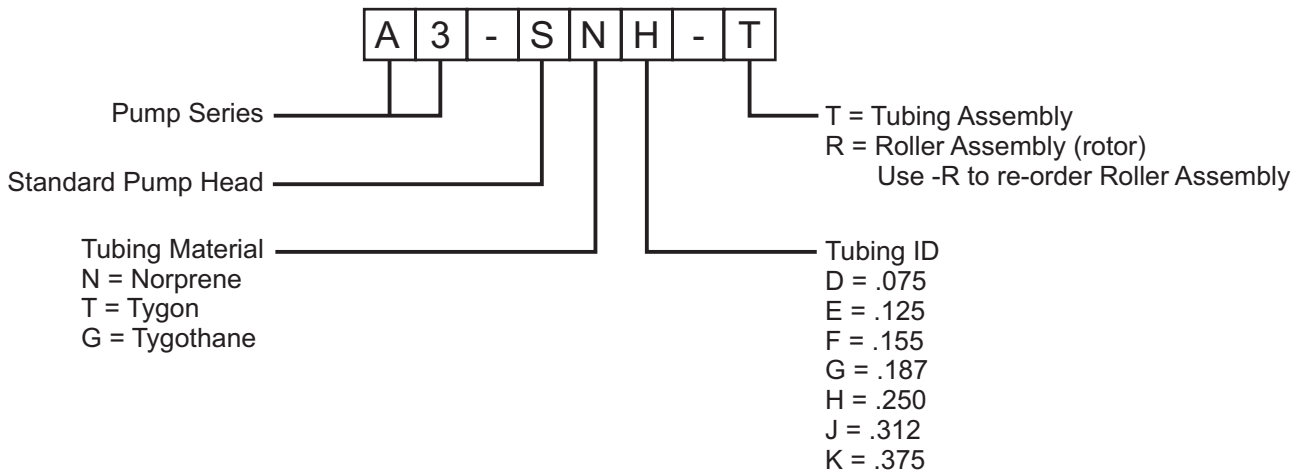

PROSERIES AUTHORIZED SERVICE CENTERS - North America

**CALIFORNIA
(NORTHERN)**
Howard E. Hutching co.
(Repair Center)
7190 Penryn Plaza
Penryn, CA 95663
800-568-3958

**CALIFORNIA
(SOUTHERN)**
Blue-White Industries
(Repair Center)
5300 Business Drive
Huntington Bch. CA 92649
714-893-8529

ILLINOIS
Mullarkey Associates
(Repair Center)
12346 S. Keeler Ave.
Alsip, IL 60658
708-597-5558

NEW YORK
Sherwood Specialties,
Inc.
(Repair Center)
875 Atlantic Ave
Rochester, NY 14608
585-546-1211

NORTH CAROLINA
Southern Industrial Sales
(Repair Center)
1903 Herring Avenue
Wilson, NC 27893
800-872-7665

CANADA
McPhee Enterprises
(Repair Center)
2740 Coventry Road
Oakville, Ontario L6H 6R1

LIMITED WARRANTY

Your new pump is a quality product and is warranted for 24 months from date of purchase (proof of purchase is required). The pump will be repaired or replaced at our discretion.

WHAT IS NOT COVERED

1. **Pump Tube Assemblies and rubber components – They are perishable and require periodic replacement.**
2. **Pump removal, or re-installation, and any related labor charge.**
3. **Freight to the factory, or ProSeries service center.**
4. **Pumps that have been tampered with, or in pieces.**
5. **Pumps damaged by Chemical, faulty wiring or acts of nature.**

Warranty coverage does not include damage to the pump that results from misuse, carelessness, abuse or alteration which is out of our control. Blue-White Industries does not assume responsibility for any loss, damage, or expense directly or indirectly related to or arising out of the use of its products.

Warranty status is determined by the pump's serial label and the sales invoice or receipt. The serial label must be on the pump and legible. The warranty status of the pump will be verified by Blue-White or a factory authorized service center.

OTHER IMPORTANT WARRANTY INFORMATION

Please be advised; injection and metering devices are not intended as a means of treating water to render it suitable for human consumption. When used as hypochlorinators, they are meant to destroy bacteria and algae contamination, before its removal by filtration. Acid and soda injectors are used for PH control (balance). Blue-White injectors are factory tested with water only for pressure and performance. Installers and operators of these devices must be well informed and aware of the precautions to be taken when injecting various chemicals -especially those considered hazardous or dangerous, eye protection must be worn when working around this product or any other metering type of pump.

Should it become necessary to return the pump for repair or service, you must attach information regarding the chemical used as some residue may be present within the unit which could be a hazard to service personnel. Blue-White Industries will not be liable for any damage that may result by the use of chemicals with their injectors and its components. Thank you.

PROCEDURE FOR IN WARRANTY REPAIR

Carefully pack the pump to be repaired. It is recommended to include foot strainer and injection/check valve fitting since these devices may be clogged and part of the problem. Please enclose a brief description of the problem as well as the original invoice or sales receipt, or copy showing the date of purchase. Prepay all shipping costs. No COD shipments they will not be accepted. Warranty service must be performed by the factory or an authorized ProSeries service center. Damage caused by improper packaging is the responsibility of the sender. When In-Warranty repair or replacement is completed, the factory pays for return shipping to the dealer or customer.



Users of electrical and electronic equipment (EEE) with the WEEE marking per Annex IV of the WEEE Directive must not dispose of end of life EEE as unsorted municipal waste, but use the collection framework available to them for the return, recycle, recovery of WEEE and minimize any potential effects of EEE on the environment and human health due to the presence of hazardous substances.

The WEEE marking applies only to countries within the European Union (EU) and Norway. Appliances are labeled in accordance with European Directive 2002/96/EC.

Contact your local waste recovery agency for a *Designated Collection Facility* in your area.